



VENTILATING UNITS

INSTALLATION INSTRUCTIONS:

1. Install unit according to arrow on housing, this indicates direction of airflow to outside atmosphere. Unit should be firmly bolted to booth and duct work to avoid excessive vibration.
2. Arrow on fan indicates proper fan rotation. Make sure motor is wired to rotate fan properly.
3. **Note:** Motor is to be mounted on plate provided. Make sure motor is firmly secured. Adjust plate for proper belt tension.
4. Access door on housing is optional for servicing fan, shaft and bearings. When mounting unit, make sure the Access Door is free from any obstruction.
5. All vent units are equipped with (2) two angle iron rings.
BE-54-12 Diameter Ring BE-54-33 Diameter Ring
BE-54-18 Diameter Ring BE-54-43 Diameter Ring
BE-54-24 Diameter Ring
All Paasche Units have sealed ball bearings.

WARNING: Spray materials may be harmful if inhaled or allowed to come into contact with skin or eyes. Consult the product label and Material Safety Data Sheet supplied for the spray material. Follow all safety precautions. Use in Well Ventilated Area to remove fumes, dust or overspray. Maintenance should always be performed by experienced and trained personnel (lock out-tag out). **Regular maintenance checks for paint residue must be performed to remove any fire hazard. The fan should be checked for build-up and kept clean. Paint Filters must be changed frequently.**

BEARING & SHAFT ASSEMBLY FOR B12- THRU B42- VENTS

1. Insert shaft through bearing.
2. Push counterbored side of collar over inner race of bearing.
3. Lock collar into place with a right turn.
4. Tighten set screw.

SIZE	H.P.	A	B	C	D	NO. OF HOLES
B12-	1/4	12"	12"	14-1/16"	13-3/16"	4
B18-	1/4, 1/3, 1/2, 3/4	14"	18"	20- 3/32"	19-1/4"	4
B24-	1/2, 3/4, 1, 1-1/2, 2	17"	24"	26-3/32"	25-1/4"	8
B32-	2, 3, 5	19"	33-1/8"	35-3/4"	34-3/4"	8
B42-	3, 5	24"	43-1/4"	45-3/4"	44-3/4"	8

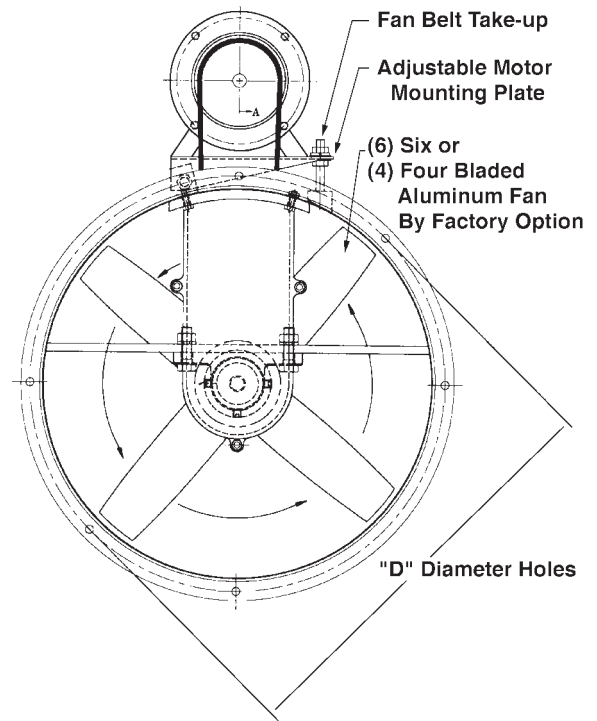
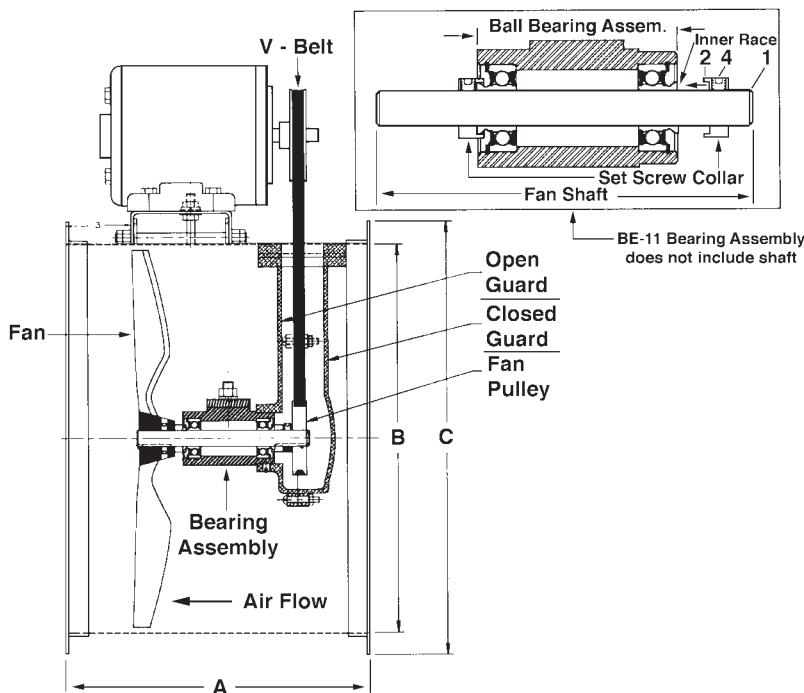

Paasche Airbrush Company
 4311 North Normandy Avenue
 Chicago, IL 60634-1395
 Phone: 773-867-9191 • Fax: 773-867-9198
 Website: paascheairbrush.com
 E-Mail: info@paascheairbrush.com

B12-1/4 H.P. VENT UNIT L/MOTOR

Specify 48 or 56 NEMA Frame	
AK-26-1/2"	Motor Pulley (48)
AK-26-5/8"	Motor Pulley (56)
AK-22-5/8"	Fan Pulley
4L-280	(1) "V" Belt (48)
4L-290	(1) "V" Belt (56)
BE-98	12" Fan Blade, 5/8"B.
BE-106	Fan Shaft 5/8" Diameter
BE-164	Ball Bearing Assembly
BE-107	5/8" Ball Bearing
S1010K	5/8" Bore Locking Collar
BE-159	Belt Guard - Open
BE-160	Belt Guard - Closed

B18-1/4 H.P. VENT UNIT L/MOTOR

Specify 48 or 56 NEMA Frame	
AK-30-1/2"	Motor Pulley (48)
AK-30-5/8"	Motor Pulley (56)
AK-34-3/4"	Fan Pulley
4L-370	(1) "V" Belt (48)
4L-380	(1) "V" Belt (56)
BE-165	17-1/2" Fan Blade, 3/4" B.
BE-21A	Fan Shaft 3/4" Diameter
BE-11	Ball Bearing Assembly
BE-146	3/4" Ball Bearing
S1012K	3/4" Bore Locking Collar
BE-7A	Belt Guard-Open
BE-8A	Belt Guard-Closed

B18-1/3 H.P. VENT UNIT L/MOTOR

Specify 48 or 56 NEMA Frame	
AK-32-1/2"	Motor Pulley (48)
AK-32-5/8"	Motor Pulley (56)
AK-34-3/4"	Fan Pulley
4L-370	(1) "V" Belt (48)
4L-380	(1) "V" Belt (56)

Balance of items same as B18-1/4 above.

B18-1/2 H.P. VENT UNIT L/MOTOR

Specify 48 or 56 NEMA Frame	
AK-39-1/2"	Motor Pulley (48)
AK-39-5/8"	Motor Pulley (56)
AK-34-3/4"	Fan Pulley
4L-380	(1) "V" Belt (48)
4L-390	(1) "V" Belt (56)

Balance of items same as B18-1/4 above.

B18-3/4 H.P. VENT UNIT L/MOTOR

Specify 56 NEMA Frame	
AK-44-5/8"	Motor Pulley (56)
AK-34-3/4"	Fan Pulley
4L-400	(1) "V" Belt (56)

Balance of items same as B18-1/4 above.

B24-1/2 H.P. VENT UNIT L/MOTOR

Specify 48 or 56 NEMA Frame	
AK-20-1/2"	Motor Pulley (48)
AK-20-5/8"	Motor Pulley (56)
2AK-32-3/4"	Fan Pulley
4L-420	(1) "V" Belt (48)
4L-430	(1) "V" Belt (56)
BE-166	23-1/2" Fan Blade, 3/4" B.
BE-21A	Fan Shaft, 3/4" Diameter
BE-11	Ball Bearing Assembly
BE-146	3/4" Ball Bearing
S1012K	3/4" Bore Locking Collar
BE-9A	Belt Guard-Open
BE-51A	Belt Guard-Closed

B24-3/4 H.P. VENT UNIT L/MOTOR

Specify 56 NEMA Frame	
2AK-23-5/8"	Motor Pulley (56)
2AK-32-3/4"	Fan Pulley
4L-430	(2) "V" Belt (56)

Balance of items same as B24-1/2 below.

B24-1 H.P. VENT UNIT L/MOTOR

Specify 56 or 143T NEMA Frame	
2AK-26-5/8"	Motor Pulley (56)
2AK-26-7/8"	Motor Pulley (143T)
2AK-32-3/4"	Fan Pulley
4L-440	(2) "V" Belt (56 & 143T)

Balance of items same as B24-1/2 below.

B24-1-1/2 H.P. VENT UNIT L/MOTOR

Specify 56, 145T or 184 NEMA Frame	
2AK-30-5/8"	Motor Pulley (56)
2AK-30-7/8"	Motor Pulley (145T & 184)
2AK-32-3/4"	Fan Pulley
4L-450	(2) "V" Belt (56 & 145T)
4L-470	(2) "V" Belt (184)

Balance of items same as B24-1/2 below.

B24-2 H.P. VENT UNIT L/MOTOR

Specify 56, 145T or 182T NEMA Frame	
2AK-32-5/8"	Motor Pulley (56)
2AK-32-7/8"	Motor Pulley (145T)
2AK-32-1-1/8"	Motor Pulley (182T)
2AK-32-3/4"	Fan Pulley
4L-450	(2) "V" Belt (56 & 145T)
4L-470	(2) "V" Belt (182T)

Balance of items same as B24-1/2 below.

B32-2A22 2 H.P. VENT UNIT L/MOTOR

Specify 56 or 145T NEMA Frame	
2AK-22-5/8"	Motor Pulley (56)
2AK-22-7/8"	Motor Pulley (145T)
2TB-44-1-3/16"	Fan Pulley w/Bushing
AX53	(2) "V" Belts (56 & 145T)
BE-167	32" Fan Blade, 1-3/16"B.
BE-67	Fan Shaft, 1-3/16" Diameter
BE-105	Ball Bearing Assembly
BE-92	1-3/16" Ball Bearing
BE-150	1-3/16" Lock Collar
BE-63A	Belt Guard-Open
BE-62A	Belt Guard-Closed

B32-2A23 2 H.P. VENT UNIT L/MOTOR

Specify 56 or 145T NEMA Frame	
2AK-23-5/8"	Motor Pulley (56)
2AK-23-7/8"	Motor Pulley (145T)
2TB-44-1-3/16"	Fan Pulley w/Bushing
AX53	(2) "V" Belts (56 & 145T)

Balance of items same as B32-2A22 above.

B32-3B30 3 H.P. VENT UNIT L/MOTOR

Specify 182T NEMA Frame	
2AK-30-1-1/8"	Motor Pulley
2TB-44-1-3/16"	Fan Pulley w/Bushing
AX55	(2) "V" Belts

Balance of items same as B32-2A22 above.

B32-3B32 3 H.P. VENT UNIT L/MOTOR

Specify 182T NEMA Frame	
2BK-32-1-1/8"	Motor Pulley
2TB-44-1-3/16"	Fan Pulley w/Bushing
AX55	(2) "V" Belts

Balance of items same as B32-2A22 above.

B32-5B32 5 H.P. VENT UNIT L/MOTOR

Specify 184T NEMA Frame	
2BK-32-1-1/8"	Motor Pulley
2TB-44-1-3/16"	Fan Pulley w/Bushing
BX56	(2) "V" Belts

Balance of items same as B32-2A22 below.

B32-5B34 5 H.P. VENT UNIT L/MOTOR

Specify 184T NEMA Frame	
2BK-34-1-1/8"	Motor Pulley
2TB-44-1-3/16"	Fan Pulley w/Bushing
BX56	(2) "V" Belts

Balance of items same as B32-2A22 below.

B32-5B36 5 H.P. VENT UNIT L/MOTOR

Specify 184T NEMA Frame	
2BK-36-1-1/8"	Motor Pulley
2TB-44-1-3/16"	Fan Pulley w/Bushing
BX56	(2) "V" Belts

Balance of items same as B32-2A22 below.

B42-3B28 3 H.P. VENT UNIT L/MOTOR

Specify 182T NEMA Frame	
2BK-28-1-1/8"	Motor Pulley
2TB-68-1-3/16"	Fan Pulley w/Bushing
BX75	(2) "V" Belts
BE-170	42" Fan Blade, 1-3/16"B.
BE-67	Fan Shaft, 1-3/16" Dia.
BE-105	Ball Bearing Assembly
BE-92	1-3/16" Ball Bearing
BE-150	1-3/16" Locking Collar

B42-3B30 3 H.P. VENT UNIT L/MOTOR

Specify 182T NEMA Frame	
2BK-30-1-1/8"	Motor Pulley
2TB-68-1-3/16"	Fan Pulley w/Bushing
BX75	(2) "V" Belts
BE-170	42" Fan Blade, 1-3/16"B.
BE-67	Fan Shaft, 1-3/16" Dia.
BE-105	Ball Bearing Assembly
BE-92	1-3/16" Ball Bearing
BE-150	1-3/16" Locking Collar

B42-5B36 5 H.P. VENT UNIT L/MOTOR

Specify 184T NEMA Frame	
2BK-36-1-1/8"	Motor Pulley
2TB-68-1-3/16"	Fan Pulley w/Bushing
BX75	(2) "V" Belts
BE-170	42" Fan Blade, 1-3/16"B.
BE-67	Fan Shaft, 1-3/16" Dia.
BE-105	Ball Bearing Assembly
BE-92	1-3/16" Ball Bearing
BE-150	1-3/16" Locking Collar