



VSR90#1

Gravity Feed - Internal Mix- Double Action Airbrush

WARNING: Spray materials may be harmful if inhaled or allowed to come into contact with the skin or eyes. Consult the product label and Material Safety Data Sheet supplied for the spray material. Follow all safety precautions. **CAUTION:** Well Ventilated Area Required to remove fumes, dust or overspray. Secure airhose to Airbrush with V-62 Wrench for safety and to prevent air leaks.
Maximum Air Pressure 75 P.S.I.



INTRODUCTION:

Prime Characteristics of the Paasche® VSR90#1 Airbrush include the ability to spray fluids requiring gravity feed as well as make quick color changes with the two (2) different size color cups supplied with each set. This unique two in one design allows the user choice of cup size while using only one shell. These color cups enable the user to swivel each cup right, left or in alignment with the shell to allow an unobstructed view of their efforts. The Double Action, Internal mix feature permits flexibility in regulation of color and air without work stoppage. The two different size Multipleheads, Tips and Needles are quickly interchangeable to allow greater diversity in materials and coverage.

Head Sizes - Patterns - Fluid Thickness

- Size 1 - Tip size .010 inches or .25mm
- Used for fine detail. Pencil Line to 1" patterns
- Paint must be thinned further than 3 & 5 heads
- Size 2 -Tip size .026 inches or .66mm
- Less detail than the size 1 head. 1/32" to 1-1/2" patterns
- Can spray slightly thicker paint than size 1 head

Working Pressures:

- Operating pressures 20-55 PSI; Maximum pressure 75 PSI
- 20-30 PSI is best for detail spraying w/ properly thinned paint
- Use the higher pressures for thicker material where fine detail is not critical or thin the paint to allow lower pressures.

Equipment Set-up:

The Airbrush is held in the same manner as a pen, with the index finger comfortably over the finger button.

1. Attach airhose to air supply and to airbrush. If regulator set pressure between 20 -30 PSI.
2. For VSR90#1 attach one of the color cups to color socket.
3. Remove Head Protecting Cap- #1 page 2.

Airbrush Operation:

1. Press down on Finger Button to release air and pull back on button to control quantity of color.
2. To spray a fine line without heavy ends, start moving the airbrush without release of color. Then start the color at the beginning of line and stop the color at the end, but continue the motion of the airbrush after the color has stopped.
3. Practice this movement until you can spray a fine line or a broad pattern without heavy build up at the beginning or end of your strokes.
4. Speed of movement controls density of color and fading effects at beginning and end of strokes.
5. For detail, hold the airbrush very close to the surface push down for air and pull back very slowly on the Finger Button to release a small amount of paint.
6. For background work and broad effects, hold the airbrush away from the work surface and pull back on Finger Button to release required amount of color.
7. For Stippling remove the aircap, push down on the trigger and pump the trigger forward and back. Adjust the air pressure between 15 and 50 PSI for desired stipple effect.
8. For more instruction see the "22 Airbrush Lessons for Beginners" booklet enclosed with your airbrush.

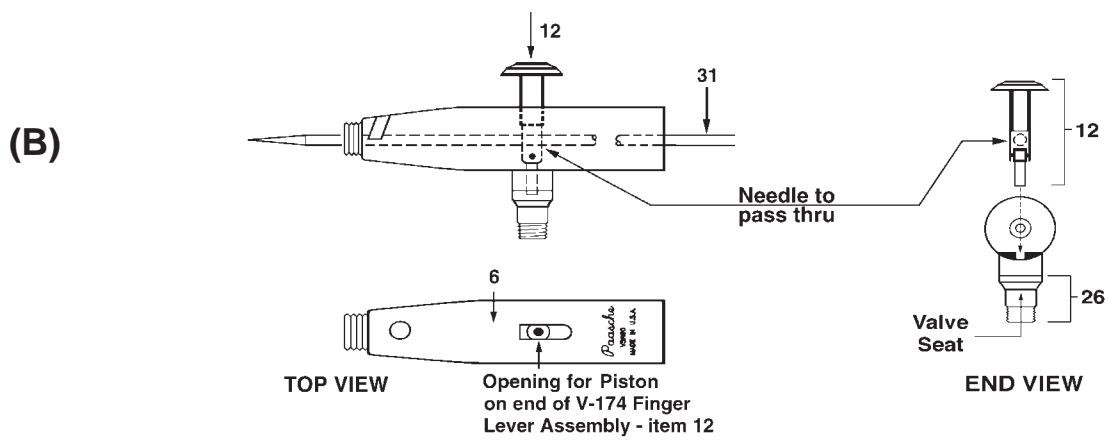
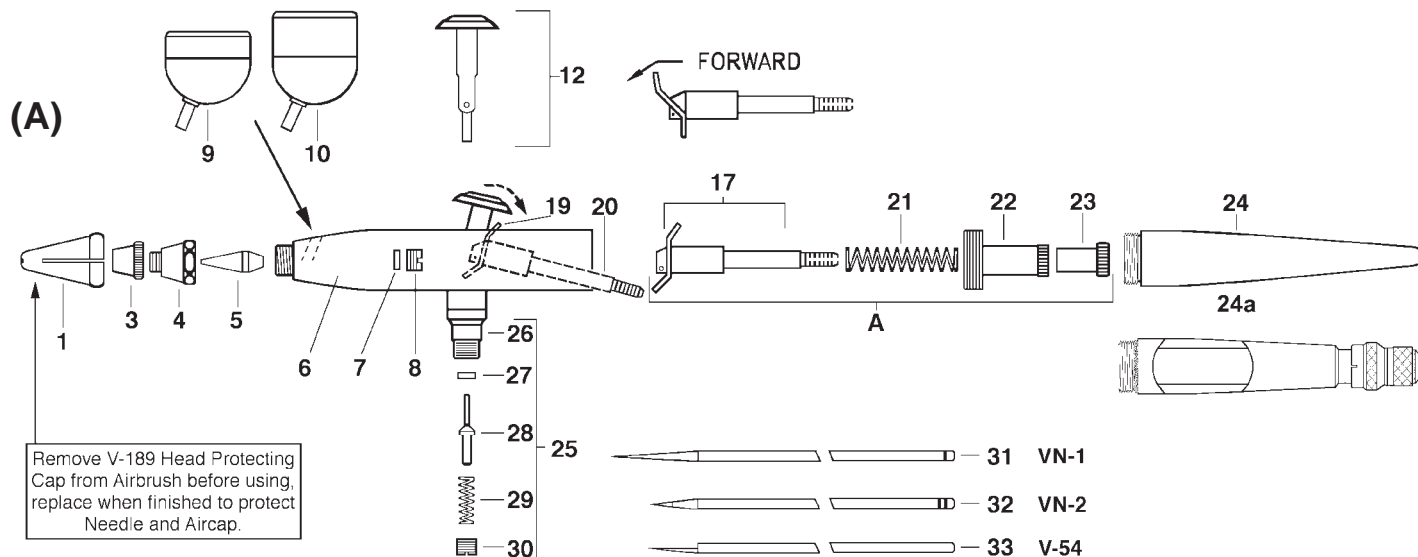

<u>NO.</u>	<u>PART</u>	<u>DESCRIPTION</u>	<u>NO.</u>	<u>PART</u>	<u>DESCRIPTION</u>
1.	V-189	Head Protecting Cap	24.	AFV-143	Chrome Plated Metal Handle
4.	VB	Aircap Body	24a.	TAL-34	Handle & Stop Assembly (Optional) -allows for preset paint flow
	<u>VM-1 or 2</u>	<u>Multiplehead (Select Size)</u>			
3.	VA-1 or 2	Aircap (Select Size)	25.	V-176	Air Valve Assembly
31 or 32.	VN-1 or 2	Needle (Select Size)	26.	V-20	Valve Casing
5.	VT-1 or 2	Tip (Select Size)	27.	A-52	Valve Washer (Price/Doz.)
6.	V-210	Shell Assembly W/V-20	28.	H-21A	Valve Plunger
7.	V-83	Packing Teflon®	29.	A-22	Valve Spring
8.	V-84	Nut	30.	A-23A	Air Valve Nut
9.	VSR-1	Color Cup 1/8 oz. (3.5cc)	31.	VN-1	Needle (Select Size)
10.	VSR-2	Color Cup 3/16 oz. (5.25cc)	32.	VN-2	Needle (Select Size)
12.	V-174	Finger Lever Assembly	33.	V-54	Reamer
A.	V-186	Needle Valve Assembly L/Needle			
17.	V-191A	Rocker Assembly			
21.	V-140	Spring			
22.	V-136A	Needle Adjusting Sleeve			
23.	V-141	Locknut			

REMOVING/REPLACING THE NEEDLE AND HANDLE (Illustration A):

1. Unscrew the handle and loosen the Locknut-#23 by turning counterclockwise. Depress the Finger Lever Assembly-#12 and hold in Down position while removing or inserting the needle. This assures the needle moves freely through the finger lever. Gently remove the needle, rotating if necessary, Do NOT force out!
2. A loose needle can cause sputtering if there is any air leakage around the needle and Packing-#7. If there is no noticeable drag on the needle by the packing then tighten Nut-#8.
3. Inspect the condition of the needle. If it is bent or misshapen in any way, replace it with a new needle. A bent needle can damage or split the Tip-#5 causing bubbles or a rough spray pattern.
4. Hold Trigger Assembly in DOWN position, insert the new needle into the Rocker Assembly-#17. Gently push needle through, rotating if necessary, push gently forward until the needle stops in the front of the tip.
5. Release Finger Lever Assembly and tighten Locknut by turning clockwise.

REPLACING THE FINGER LEVER ASSEMBLY (Illustration B):

If the Finger Lever -#12 is removed, it must be replaced inside the airbrush shell, before the Rocker Assembly-#17 and needle are re-inserted.

1. Hold Finger Lever Assembly so the opening in the lever is in-line with the opening in the end of the airbrush shell (see B - END VIEW).
2. The Piston, which pivots on the end of the Finger Lever, must be kept in DOWN position.
3. Insert Finger Lever Assembly with piston straight DOWN through the opening in the top of the airbrush shell (see B - TOP VIEW). Make sure the Piston goes down into the base opening of the Valve Casing-#26 (inside shell-see B). Sometimes this takes several tries. Take your time.
4. Once the Piston, of the Finger Lever Assembly, has been inserted into the Valve Casing, you will be able to press down on the Finger Button and it will return to the up position when released. Proceed to replace Rocker Assembly and balance of parts as above. The needle when inserted will prevent the removal of the finger lever assembly.

REPLACING THE TIP:

1. Remove handle, loosen Locknut-#23 and withdraw needle about one inch (1").
2. Un-screw the Aircap Body-#4 and remove. The Tip-#5 can now be easily removed by hand. If stuck in shell tap lightly with wrench.
3. Place a new Tip into position and tighten Aircap Body to shell with a wrench. Push needle forward until it seats fully forward in tip and tighten Locknut.

ADJUSTING WORN PACKING WASHER:

1. If Packing Washer-#7 becomes worn or loose it must be tightened or replaced
2. Tighten Packing Nut-#8 with small screwdriver. To reach packing guts of airbrush must be removed.
3. Replace needle and make sure Packing Nut is not too tight. A slight resistance to movement is needed when needle is passed through.
4. Completely re-assemble guts of airbrush.

CLEANING THE AIRBRUSH:

1. Paint passes from the bottle connection forward so the trigger area back will most likely not need cleaning.
2. You can back flush the paint into your bottle by covering the aircap with your finger pressing down on the trigger and pulling slightly back. This forces paint from the fluid passage back into the bottle. **If using open cup, cover before back flushing.**
3. In between color changes or before storing the airbrush attach bottle with paint cleaner and spray until it runs clear.
4. Remove needle and wipe clean then replace.
5. If paint has dried for a time you can remove the front tip, aircap and aircap body for soaking or soak just the front of the airbrush in cleaner.
6. Any paint cleaner is fine. Keep trigger area dry if soaking.

PERSONAL SETTINGS:

Needle Adjustment Sleeve- Used to increase or decrease spring tension for the trigger pull back. Thread into the shell until the trigger stroke feels comfortable. Threading in until it stops can cause the trigger to jam.

TROUBLESHOOTING:**Bubbling in cup**

1. VB Aircap Body #4 needs to be wrench tightened

Skipping or Spitting:

- | | |
|--------------------------------|---|
| 1. Paint too thick | -Reduce with thinner |
| 2. Tip not seated | -Tighten VLB aircap body with wrench |
| 3. Tip split or damaged Needle | -Replace tip or needle |
| 4. Needle or tip dirty | -Clean and replace |
| 5. Air pressure too low | -Increase pressure or thin paint further (need 20 or more PSI to spray most paints) |

Airbrush Not Spraying:

- | | |
|-----------------------------|---|
| 1. Clogged Tip | -Remove tip and clean |
| 2. Needle not moving | -Tighten needle locknut |
| 3. Loose VLB aircap body | -Wrench tighten |
| 4. Low air pressure | -Increase pressure (need 20 or more PSI to spray most paints) |
| 5. Bottle vent hole plugged | -Use needle or pin to clear air hole |

Sprays double line or heavy to one side:

- | | |
|-------------------------------|--|
| 1. Split tip or bent needle | - Replace |
| 2. Dirty tip or needle | - Remove and clean |
| 3. Tip not centered in aircap | - Remove head and clean airbrush seat and tip seat then reassemble. Use wrench for aircap body |

Jammed trigger or poor trigger motion:

- | | |
|----------------------------------|---|
| 1. Adjust Needle Adj. Sleeve | - Screw or unscrew the sleeve to lessen or increase tension on trigger motion |
| 2. Paint leaking to trigger area | - Remove guts of airbrush and slightly tighten packing or replace if needed |
| 3. Lubricate needle and trigger | - Apply lubricant to needle shaft and trigger slot area |

AIRHOSES W/FACTORY INSTALLED COUPLINGS

- 34. **A-1/8** Braided Airhose W/Couplings
- 35. **HP-1/8** Red-Plastic Airhose W/Couplings

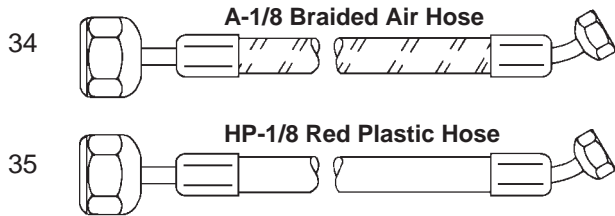

ACCESSORIES

- 36. **A-34** Hanger
- 37. **V-62** Wrench

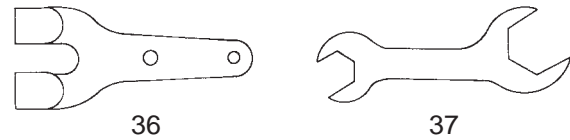

COUPLINGS - OLD STYLE REPLACEMENTS

- 38. **AC-1/8** Coupling (To Compressor)
- 39. **AC-20** Coupling (To Airbrush)

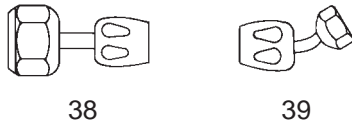

CUPS

- 40. **VSR-1** 1/8 oz. (3.5cc) Cup
- 41. **VSR-2** 3/16 oz. (5.25cc) Cup

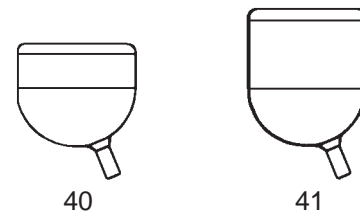

MT MOISTURE TRAP INSTALLATION

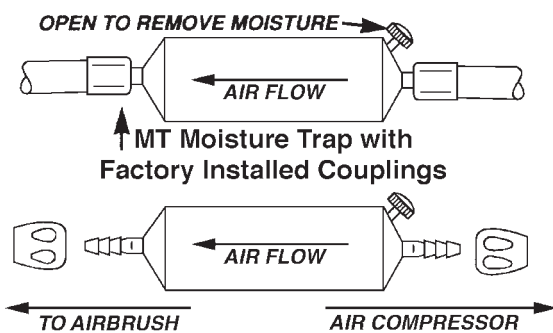

Do-It-Yourself Installation: The Moisture Trap is designed for use with all Airbrushes to remove water from the airline. To install-cut the airhose about 18" from the Airbrush coupling and insert as illustrated.

Recommended Compressors and Accessories



D200R AIR COMPRESSOR (1/6 H.P.) with Switch UL Listed & R-75 Regulator
Perfect for hobbies requiring increased pressure for atomizing heavier materials. Delivers up to 35 psi operating pressure. It operates on 115 Volts, 60Hz, 1.5AMPS and delivers .7 CFM @ 20 psi.
Shipping Weight: 13 lbs. (5.9 kg)



D500 AIR COMPRESSOR (1/8 H.P.) (ETL Listed)
Economical and suitable for all airbrushes spraying properly thinned fluids. It is capable of delivering up to 35 P.S.I. operating pressure depending on airbrush being used. The Paasche D500 is an oilless piston compressor. It operates on 110-120 Volt, 1 phase, 60Hz, and delivers 4 C.F.M. @ 20 P.S.I.
Shipping Weight: 8 lbs. (3.6kg)



DA300R AIR COMPRESSOR (1/6 H.P.) with Switch CSA approved & R-75 Regulator
1/8 H.P. Piston Compressor with Auto shutoff. Compressor shuts off when airbrush is not in use. Operating pressure is 20 - 30 P.S.I. depending on airbrush being used, delivers up to 35 psi. 120 VAC, 1 Ph, 60 Hz, 1.4 A, 20L/Min. (0.7CFM), Noise 53dB, 1720 rpm.
Shipping Weight: 9.14 lbs. (4.6 kgs)



D3000R AIR COMPRESSOR (1/8 HP) (ETL Listed)
This piston compressor is a tank mounted unit, designed for compactness and portability. The sturdy air tank stores reserve air volume and reduces pulsation. Air pressure in the tank is regulated with an automatic on/off limit switch to a maximum of 40 P.S.I. Unit maintains 30 P.S.I. for extended periods. The unit has a five foot grounded 3 wire cord. The compressor features a 1/8 HP motor which operates on 115 Volts, 1 Phase, 60Hz and draws .9 AMPS.
Shipping Weight: 14 lbs. (6.33kg)