



L - Sprayer Handpiece and L-SC Metal Cup Assembly

Note: Must be ordered together in matching sizes.

OPERATING INSTRUCTIONS AND REPLACEMENT PARTS

APPLICATION:

The Paasche "L" Sprayer has a wide variety of uses in applying liquids of varied consistency. It is an ideal siphon type sprayer for painting small items. It will handle paints, varnishes, bronzes, lacquers, oils, cleaning solutions, disinfectants, foundry mold compounds, etc.. It is one of the easiest sprayers to use and is well constructed and simple to operate with no complicated adjustments.

AIR SUPPLY:

Air pressure may range from 10 to 60 lbs., depending on the material used and the type of work to be done.

1. Stipple and granulated effects require 5 to 25 lbs. air pressure depending upon consistency of material used.
2. Air capacity of tips range from 1-1/2 to 6 C.F.M. depending on the size of tip and the amount of air pressure used.

INTERCHANGEABLE TIPS:

Four sizes of air and fluid tips are available. The "L" Sprayer is normally supplied with an L-2 Tip unless otherwise specified.

1. For average use, the fluid tip should be adjusted to the center of the air tip when "L" Sprayer is assembled.
2. For finer atomization and smaller spray turn fluid tip below center of air stream.
3. After proper adjustment is made, the L-10 Locknut should be tightened so that adjustment will not change.

CONNECTIONS:

Before connecting air hose to air inlet at the back of handpiece, blow out the hose to remove any accumulation of dirt or foreign matter.

1. Air connection is 1/4" pipe thread. Either 3/16" or 1/4" inside diameter air hose with 1/4" couplings should be used.

OPERATIONS:

The "L" Sprayer Handpiece should be inserted into L-210 Clamp Block to the extreme forward position and locked by tightening L-58 Lock Thumb Screw.

1. Material should be mixed thoroughly to slightly lighter consistency than recommended for ordinary sprayers.
2. Materials should be strained through a cloth or wire mesh strainer before filling cup.
3. To operate sprayer, pull back on the trigger.
4. Adjust fluid tip to give size of spray as explained above.

Paasche Airbrush Company

4311 North Normandy Avenue
Chicago, IL 60634-1395

Phone: 773-867-9191 • Fax: 773-867-9198

Website: paascheairbrush.com

E-Mail: info@paascheairbrush.com

WARNING: Spray materials may be harmful if inhaled or allowed to come into contact with the skin or eyes. Consult the product label and Material Safety Data Sheet supplied for the spray material. Follow all safety precautions.
CAUTION: Well Ventilated Area Required to remove hazardous fumes, dust or overspray. Wrench tighten air hose nut to Sprayer.
Maximum Air Pressure 75 P.S.I.

OPERATIONS CONTINUED:

Before beginning to paint, the operator should practice spraying to acquire familiarity with the sprayer and control of spray.

1. To insure uniform application apply as light a coat as possible, increasing the thickness with additional thin layers of paint.
2. Each stroke should blend uniformly into the previous stroke without runs or sags.
3. Spray full length of object to be coated releasing trigger at the end of each stroke.
4. For average work the tip of the sprayer should be held 3 to 6 inches from the surface being painted.

FINISH:

A smooth finish is assured when the spray is properly adjusted and the operator has acquired control of its application.

1. A rough or stipple finish is caused by air pressure that is too low or restricted flow of air.
2. Rough finish will be obtained when sprayer is held too far from the working surface.
3. A wet or sagging finish is caused by too much material being applied or material being too thin.

CARE AND CLEANING:

Always clean the "L" Sprayer thoroughly after use.

1. The fluid tube should be cleaned with solvent siphoned through the tip after painting operation is finished.
2. Never use alkali solutions for cleaning as they will eventually destroy the aluminum parts.
3. Air and fluid tips must be kept clean at all times to insure perfect atomization and a perfect pattern.
4. Sharp instruments should not be used in cleaning tips as they will destroy or distort the openings.

AVAILABLE CONTAINERS:

Before placing liquid in cup make sure cup is clean and free of foreign particles. L-SC is available with:

Metal Cups:

- 20SCC Quart Cup W/Screw Cover (32 oz. - .946 l)

CAUTION: When spraying any material, spray in a well Ventilated Area !

• For adjusting spray loosen L-10 Locknut and move L-Tip up or down for pattern required. Tighten L-10 after adjustment.

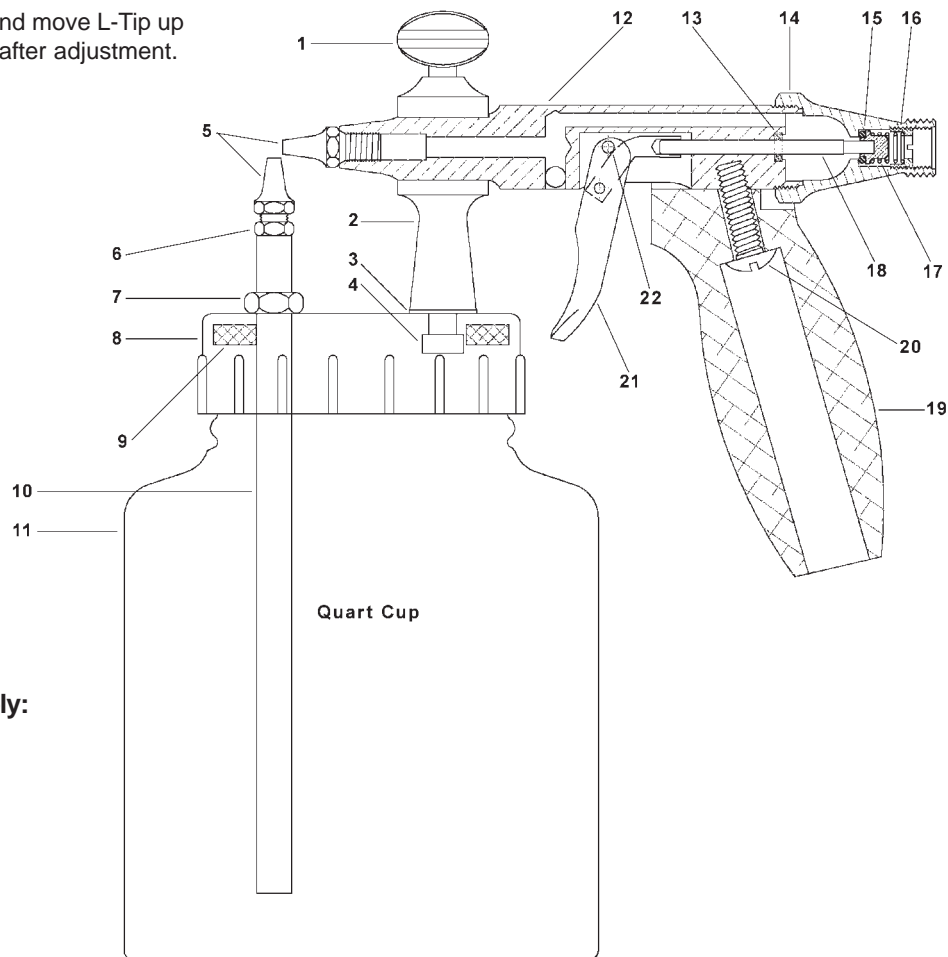
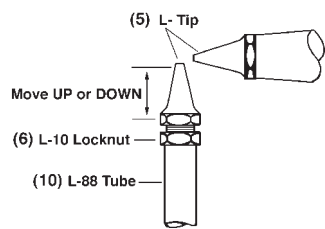

Order the following hose assembly:
HL-3/16"-8' Air Hose
w/HLC-3/16"-1/4" Couplings

IMPORTANT: You must match and order one of each, Sprayer Handpiece and Quart Cup Assembly, for Complete Set.

L#1, L#2, L#3 or L#4
SPRAYER HANDPIECE

L-SC#1, L-SC#2, L-SC#3 or L-SC#4
QUART CUP ASSEMBLY with L-87A Plastic Cover

<u>No.</u>	<u>Part No.</u>	<u>Description</u>	<u>No.</u>	<u>Part No.</u>	<u>Description</u>
1.	L-58	Lock Thumb Screw	10.	L-88-5	-1/2" Tube, Qt. Cup - (.946 l) or Pt. Jar (.473 l)
2.	L-210A	Clamp Block	11.	20SCC	Quart Cup (.946 l)
3.	5/16"ITW	Lock Washer	12.	L-71C	Shell
4.	1/4"-20X1/2"S	Socket Hd. Cap Screw	13.	H-006	"O" Ring
5.	L-1, 2, 3 or 4	Tip (Select Size)	14.	U-49A	Valve Casing
6.	L-10	Locknut	15.	U-154P	Air Valve Head
7.	L-89	Tube Locknut	16.	U-48	Nut
8.	L-87A	Cover (Standard Plastic)	17.	U-1853	Air Valve Spring
	L-87M	Cover (Metal for working in areas of high temperature)	18.	L-83A	Piston Rod
	SPECIAL: L-SC#2METAL, L-SC#4METAL QUART CUP ASSEMBLY with L-87M Metal Cover		19.	L-86	Handle
9.	3-GT	Gasket	20.	L-69	Handle Screw
			21.	L-76A	Trigger & Rod Assembly
			22.	U-40	Trigger Screw