



BUB- (Bottom Air Inlet) BUT- (Thumb Action Trigger) MANUAL SPRAY GUNS

OPERATING INSTRUCTIONS & REPLACEMENT PARTS

DESCRIPTION:

BUB- and **BUT-** Manual Spray Guns ("T" means thumb action) are for use with Light to Medium consistency materials. These models require 2 to 14 C.F.M. @ 30 to 40 P.S.I. air pressure depending on size of Multiplehead selected.

AIR CONNECTIONS:

These models have 1/4" N.P.T. Air Inlet.

1. Open air control valve and blow out Air Hose to remove any foreign particles that may be in airline. Secure air hose so it doesn't injure anyone during purging.
2. Connect air hose to the U-807 Air Inlet Tube on **BUB-** Bottom Air Inlet Model. Connect air hose to U-49A Valve Casing on **BUT-** Thumb Action Spray Gun.

FLUID CONNECTIONS:

These models have 3/8" N.P.T. Fluid Inlet.

1. For Siphon Feed, attach siphon feed cup to bottom inlet of Fluid Body Assembly.
2. For Gravity Feed, loosen U-58 Nut and then turn fluid inlet of Fluid Body Assembly to top of Spray Gun and connect Gravity Feed Cup. Tighten U-58 Nut.
3. Pressure Tank operation requires that you attach one end of fluid hose to pressure tank and the other end to the fluid inlet on the Fluid Body Assembly.

MATERIAL:

1. Mixture should be to the consistency recommended by the manufacturer.
2. Strain all materials through a cloth or fine wire mesh prior to using to insure all foreign particles have been removed.

WARNING: Spray materials may be harmful if inhaled or allowed to come into contact with the skin or eyes. Consult the product label and Material Safety Data Sheet supplied for the spray material. Follow all safety precautions.
CAUTION: Well Ventilated Area Required to remove fumes, dust or overspray. Secure airhose and fluid hose wrench tight for safety and to prevent leaks.
Maximum Air Pressure 100 P.S.I.
Maximum Fluid Pressure 45 P.S.I.

OPERATION:

1. Adjust 200-17 Fluid Knob on **BUB-** (Bottom air inlet) Model to regulate the flow of material through the Spray Gun.
2. To control fluid on the **BUT-** Spray Gun, adjust the U-1816 Adjusting Screw on the trigger.

Grip Spray Gun as you would a pistol, place two fingers on the trigger. The first one quarter inch pull releases air only and is used for cleaning by dusting surfaces before painting. Continued pull on the trigger retracts the Fluid Needle and allows maximum fluid passage.

Begin Painting by applying as light a coat as possible. Take long strokes from side to side releasing the trigger at the end of each stroke. For average work, hold head of Spray Gun 6 to 8 inches from the surface; for narrow lines, use short trigger pull and hold Spray Gun closer to the surface. To get wider spray patterns, draw Spray Gun away from surface gradually while trigger is pulled back until desired width of pattern is obtained. Practice before spraying on your project is always advisable.

CARE AND CLEANING:

Flush clean solvent through the fluid passages of the Spray Gun and wipe off the outside. Never leave the entire Spray Gun immersed in solvent or the leather packings will dry out. Dirty Aircaps and Tips should be cleaned out by soaking in solvent and then blown clean with air. Never use wire objects to ream out the holes in aircaps or tips as this will damage these items. Always follow safety instructions on cleaning solvents being used and remember to keep your containers closed in a safe location.

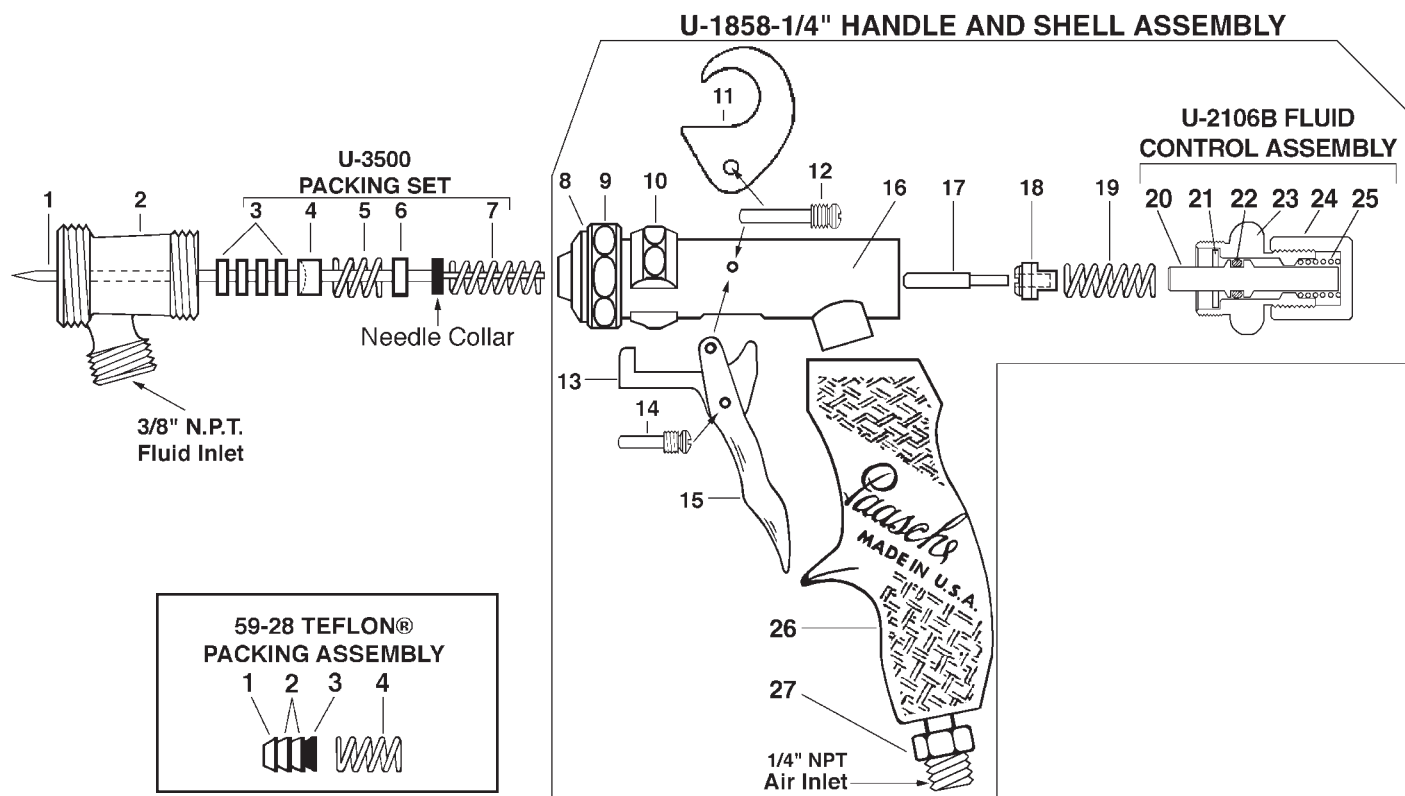

BUT- Thumb Action Spray Gun

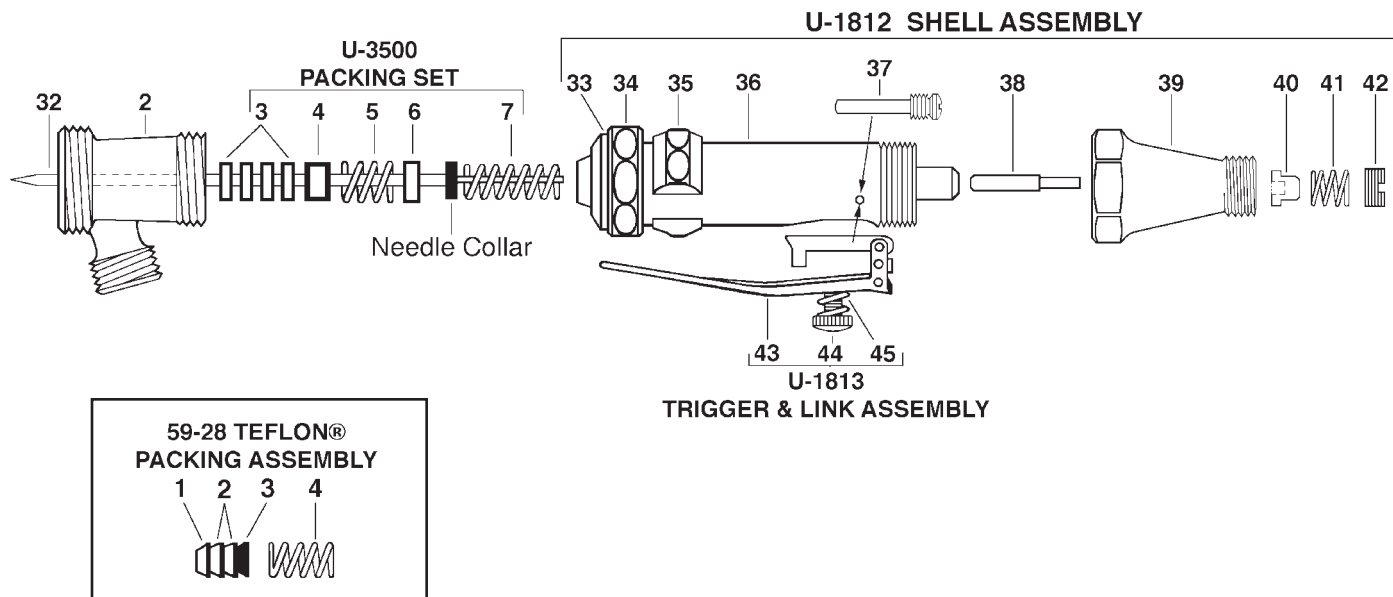

- 1. **U-2-3/8** Needle
- 2. **BU-7B** Standard Fluid Body

U-3500 Packing Set (Same on all Models)

- 3. **U-28-12** Packing Washers (4)
- 4. **U-29** Packing Gland
- 5. **DU-30** Spring *
- 6. **U-31** Spring Seat
- 7. **U-33** Spring *

Model BUB

- 1. **U-2-3/8** Needle
- Note: Not included with **U-1858-1/4**

U-1858-1/4 Handle & Shell Assembly

- 8. **U-2153** Retaining Ring
- 9. **U-58** Nut
- 10. **U-755** Link Sleeve
- 11. **U-828** Hook
- 12. **U-856** Trigger & Hook Screw *
- 13. **U-1322A** Link Assembly *
- 14. **U-35** Trigger Link Screw *
- 15. **U-1671** Trigger *
- 16. **U-2154A** Shell Assembly
- 17. **U-762** Air Valve Piston *
- 18. **U-2520P** Air Valve Head
- 19. **U-2500** Spring *

U-2106B Fluid Control Assembly (Air Inlet In Handle)

- 20. **U-3631** Plunger
- 21. **U-2750** Packing Gland
- 22. **AE-43** "O" Ring
- 23. **U-2069B** Rear Cap
- 24. **200-17** Fluid Knob
- 25. **U-1702** Valve Spring

- 26. **U-1890P** Plastic Handle
- 27. **U-807** Air Inlet Tube for **BUB- MODEL**

Model BUT

- 32. **BUT-2-1/2** Needle
- Note: Not Included with **U-1812**

U-1812 Shell Assembly

- 33. **U-2153** Retaining Ring
- 34. **U-58** Nut
- 35. **U-755** Link Sleeve
- 36. **U-1811** Shell
- 37. **U-40** Trigger Screw *
- 38. **U-194** Air Valve Piston *
- 39. **U-49A** Valve Casing
- 40. **U-154P** Air Valve Head
- 41. **U-1853** Air Valve Spring *
- 42. **U-48** Strainer Nut

U-1813 Trigger & Link Assembly

- 43. **U-193A** Trigger & Link
- 44. **U-1816** Adjusting Screw
- 45. **U-1815** Trigger Stop Spring *

59-28 Teflon® Packing Assembly (Optional)

- 1. **U-3353** Packing Teflon® (1)
- 2. **59-24** Packing Teflon® (2)
- 3. **59-25B** Packing Expander (1)
- 4. **DU-30** St. St. Spring (1) *

CONTAINERS:

- **47SCJ, 31SC, 35SC, 30SC, 34SC, other sizes available call for bulletin C & B.**

* Denotes Stainless Steel, ® DuPont

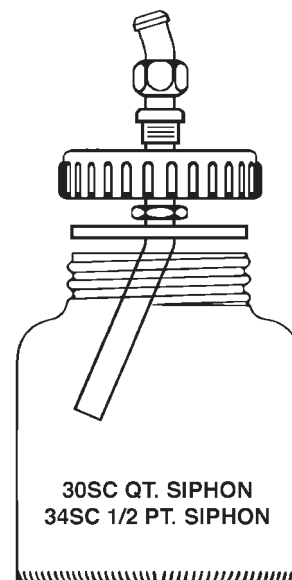
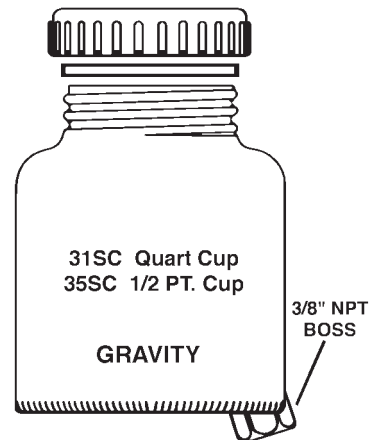
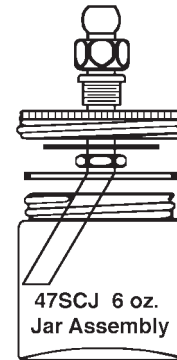

Spray Heads for BUB & BUT- Manual Spray Guns are available in several different Styles, some of which are available with Stainless Steel components. The C.F.M. requirements range from 2 to 14 C.F.M. @ 30 to 50 lbs. air pressure. NOTE: When either fluid Tip or fluid Needle is worn and requires replacement, it is recommended that both items be changed for best results. All Tips and Needles are made using 303 Stainless Steel. Carbide Tips and Needles are available for use with abrasive materials.

HVLP - HIGH VOLUME LOW PRESSURE - FAN PATTERN

when used with part No. U3609 Air Inlet Tube at maximum 50 P.S.I. Air Pressure.

- **Sizes:** 0 or 2
- 1. **BFHA-** Fan Aircap (Select Size)
- 2. **BU-12** Aircap Nut
- 3. **U-** Stainless Tip (Select Size)
- 4. **U-2-3/8** Stainless Needle

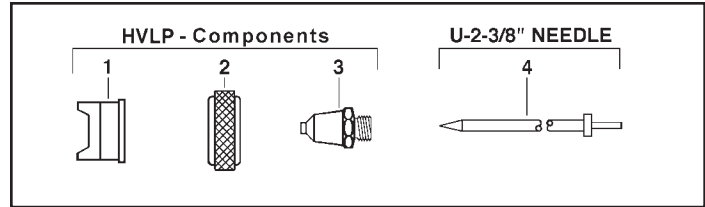

EXTERNAL- FAN PATTERN

- **Sizes:** 2, or 4
- **Application:** Hand application in tight areas.
- **Fluid Viscosity:** Light to Medium (2 to 6 C.F.M. @ 30 P.S.I.)
- 1. **BNFA-** Fan Aircap (Select Size)
- 2. **BU-12** Aircap Nut
- 3. **U-** Stainless Tip (Select Size)
- 4. **U-2-3/8** Stainless Needle for BUB- Model
BUT-2-1/2 Stainless Needle for BUT- Model

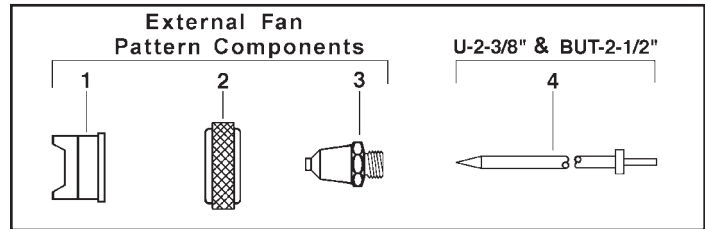

INTERNAL- ROUND PATTERN

- **Sizes:** 2 or 4
- **Application:** Fine lines, detailing stenciling and touch-up.
- **Fluid Viscosity:** Light to medium (2 to 3.5 C.F.M. @ 40 P.S.I.)
- 1. **BR-15-** Aircap Body (Select Size)
- 2. **BU-12** Aircap Nut
- 3. **U-** Stainless Tip (Select Size)
- 4. **U-2-3/8** Stainless Needle for BUB- Model
BUT-2-1/2 Stainless Needle for BUT- Model

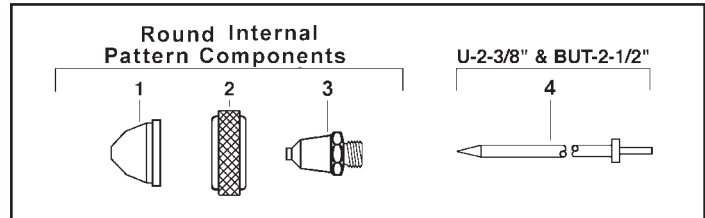

STAINLESS- INTERNAL- ROUND PATTERN

- **Sizes:** 2 or 4
- **Application:** BSR- Latex, silver nitrate, acidic materials.
- **Fluid Viscosity:** Light to medium (2 to 3.5 C.F.M. @ 40 P.S.I.)
- 1. **BSR-15-** Stainless Aircap Body
- 2. **U-** Stainless Tip (Select Size)
- 3. **BUS-12** Stainless Aircap Nut
- 4. **U-2-3/8** Stainless Needle for BUB- Model
BUT-2-1/2 Stainless Needle for BUT- Model

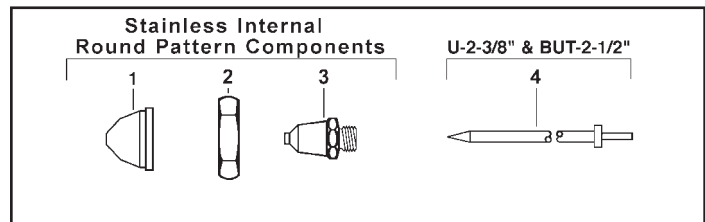

STAINLESS- EXTERNAL- FAN PATTERN

- **Sizes:** 0 only
- **Application:** Broad coverage of Latex and Corrosive materials.
- **Fluid Viscosity:** Light to Medium (3 to 5 C.F.M. @ 40 P.S.I.)
- 1. **BSF-15-** Stainless St. Fan Aircap (Select Size)
- 2. **BUS-12** Stainless Aircap Nut
- 3. **U-** Stainless Tip (Select Size)
- 4. **U-2-3/8** Stainless Needle for BUB- Model
BUT-2-1/2 Stainless Needle for BUT- Model

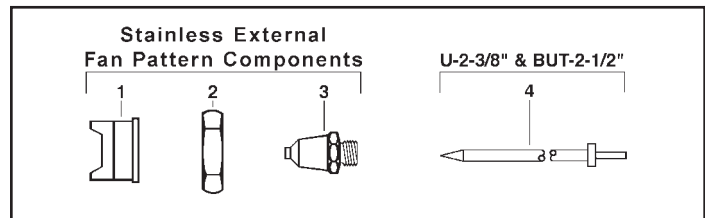

Special Tips & Needles

- **US-0, 2 or 4** Self Cleaning Tip (Select Size)
(US-0 same as U-0)
- US-0-2-3/8** Self Cleaning Needle (Match Tip Size)
- US-2-2-3/8**
- US-4-2-3/8**

