

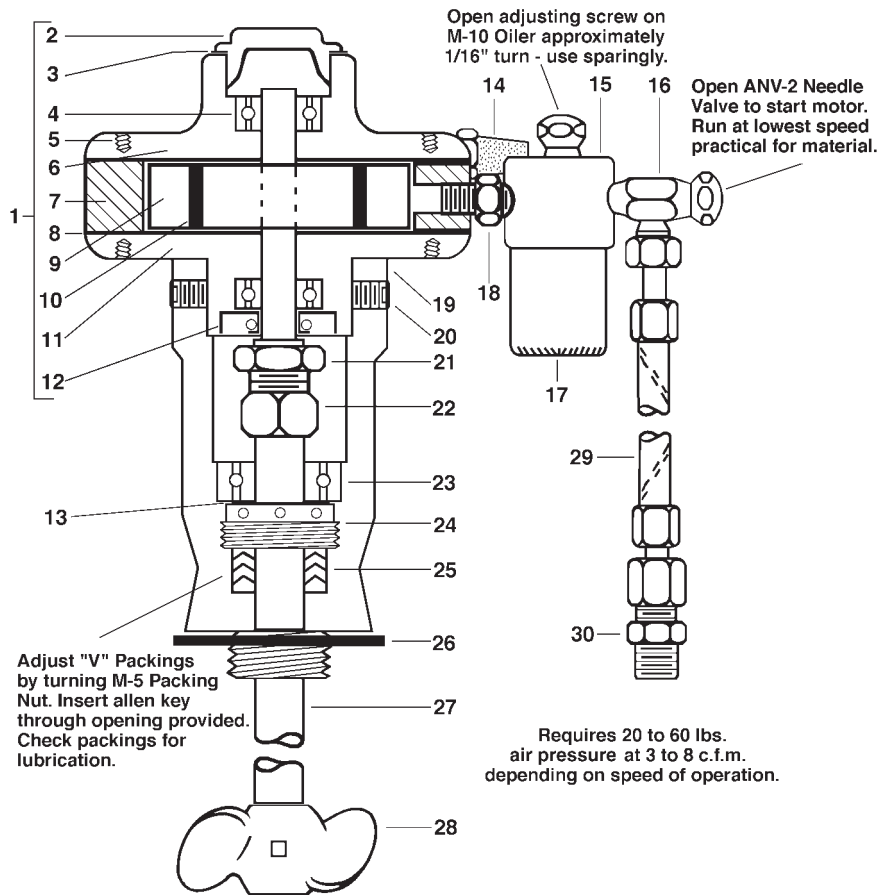

AIRMOTOR AGITATORS

#1S AIRMOTOR AGITATOR FOR ASME-A PRESSURE FEED MATERIAL TANK

WARNING: Spray materials may be harmful if inhaled or allowed to come into contact with the skin or eyes. Consult the product label and Material Safety Data Sheet supplied for the spray material. Follow all safety precautions.
CAUTION: Well Ventilated Area Required to remove fumes, dust or overspray. Secure airhoses wrench tight for safety and to prevent leaks.
MAXIMUM AIR PRESSURE 100 P.S.I.



AIRMOTOR AGITATORS:

#1S-13 Stainless Steel Airmotor Agitator
(1 Prop.) ASME-A3 Gallon

#1S-18 Stainless Steel Airmotor Agitator
(1 Prop.) ASME-A5 Gallon

#1S-23 Stainless Steel Airmotor Agitator
(1 Prop.) ASME-A10 Gallon

#1S-27 Stainless Steel Airmotor Agitator
(2 Prop.) ASME-A30 Gallon

#1S-41 Stainless Steel Airmotor Agitator
(3 Prop.) ASME-A60 Gallon

“S” Indicates Stainless Stl. Shaft & Propeller

#1S AIRMOTOR AGITATOR COMPONENTS

No.	Part No.	Description
1.	A#2	Airmotor includes items 2 thru 12
2.	M-12	Bearing Plug
3.	M-13	Bearing Plug Gasket
4.	D532	Bearing
5.	M-15	Screw (Phillips Head-12 Req.)
6.	M-16	Dead End Plate
7.	M-17	Housing
8.	M-18	End Plate Gasket
9.	M-19	Rotor Assembly
10.	M-20	Rotor Vanes (4 Req.)
11.	M-21	Drive End Plate
12.	M-22	Seal
13.	M-23	Felt Washer
14.	M-9	Muffler
15.	M-10	Oiler
16.	ANV-2	1/4" Needle Valve Assembly
17.	VF-26	Oil Cup
18.	HF-33	Coupler
19.	M-1	Bearing Housing
20.	M-2	Set Screw (3 Req.)
21.	M-29	Coupling Locknut
22.	M-28	Coupler

No.	Part No.	Description
23.	M-4	Ball Bearing
24.	M-5	Packing Nut
25.	M-6	“V” Packing (3 Req.)
26.	M-25	Gasket
27.	AGITATOR SHAFT for ASME-A TANKS	
	M7LS-13	-1/2" Shaft for ASME-A3
	M7LS-18	Shaft for ASME-A5
	M7LS-23	-1/2" Shaft for ASME-A10
	M7LS-27	-1/2" Shaft for ASME-A30
	M7LS-41	Shaft for ASME-A60

28.	#1S AIRMOTOR AGITATOR PROPELLERS	
	M-8S	Propeller for ASME-A3, A5 & A10 (1 Req.) ASME-A30 (2 Req.), ASME-A60 (3 Req.)

Letter “S” Indicates Stainless Steel Parts (M7LS or M-8S)

ACCESSORIES with AGITATOR		
29.	HL-3/16-12IN	Air Hose with Couplings HLC-3/16-1/4 Couplings both ends.
30.	HF-33	Coupler

Paasche Airbrush Company
4311 North Normandy Avenue
Chicago, IL 60634-1395
Phone: 773-867-9191 • Fax: 773-867-9198
Website: paascheairbrush.com
E-Mail: info@paascheairbrush.com

F900

Airmotor Agitators

F900 Airmotor Agitators for Gravity Feed Cups are used to agitate quick-settling materials requiring 100 to 200 R.P.M. to prevent clogging and settling and to feed materials uniformly.

F900 Airmotor Agitators can be used with 3 Oz., 1/2 Pint, Pint & Quart Aluminum Cups or Polyethylene Quart Bottles. Never use glass containers with the F900 Airmotor Agitator.

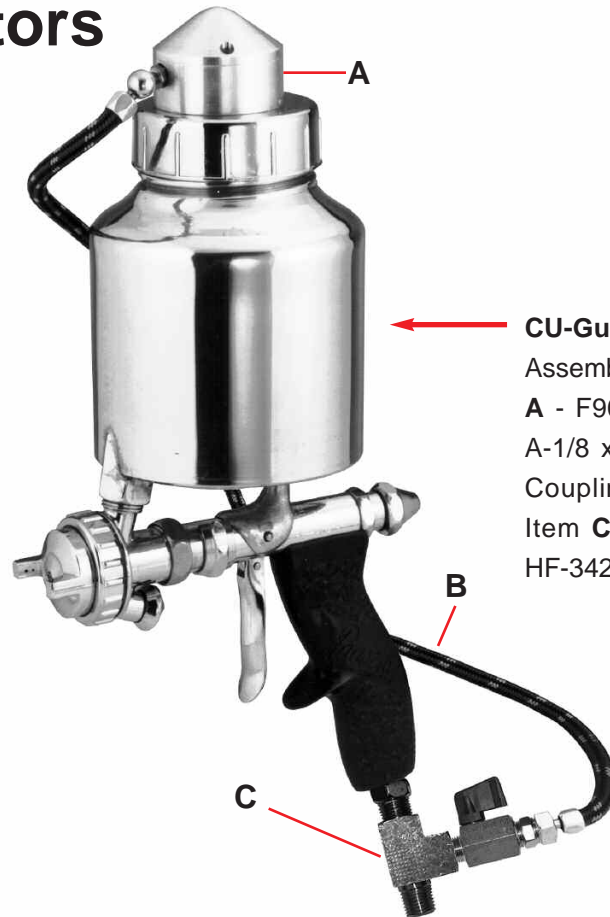

FLUID PRESSURE: Do not exceed 25 lbs. **maximum** of material pressure.

CU-Gun with F900 Airmotor Agitator Assembly for Gravity Feed Cups. Item **A** - F900 Airmotor Agitator. Item **B** - A-1/8 x 18IN Air Hose with P2-6-1/8 Coupling and AC-1/8-1/4 Coupling. Item **C** - HF-1/4 Valve Assembly & HF-342 1/4" 3 Way Tee

F900 AIRMOTOR AGITATOR PARTS LIST

No.	Part No.	Description
1.	F900-2	Airmotor Cover
2.	F900-10	Socket Head Cap Screw
3.	F900-6	Coupling (Air Inlet)
4.	F900-8	Bearing (2 Required)
5.	F900-1	Airmotor Housing
6.	F900-7	Muffler
7.	F900-3	Turbine Wheel
8.	F900-3.25	Shaft Stainless Stl. (3 oz. Grav. Cup)
	F900-4.5	Shaft Stainless Stl. (1/2 Pt., Pt., & Qt.)
	F900-8.5	Shaft Stainless Stl. (Qt. Poly Bottle)
9.	F900-5S	Propeller Stainless Steel
10.	U-3074SA	Qt. Poly. Bottle Cover (3 Holes)
11.	U-3559	1/2pt,pt & qt Gravity Cover (5 Holes)
12.	U-3564	1/2pt,pt & qt Syphon Cover (4 Holes)
13.	U-3615	27SCAA-3OZ Gravity Cover (4 Holes)
14.	00-4070	Rubber "O" Ring needed for both Syphon & Gravity Covers.(Not Shown)

☼ Covers Not Shown

