



AEC Air Eraser

Steel Tip W/Carbide Insert

OPERATING INSTRUCTIONS & REPLACEMENT PARTS

WARNING: Read instructions for proper care in handling and operation. Always wear a Respirator and Goggles when using the AEC Air Eraser. Use in Well Ventilated Area to remove dust. Always read and follow Cautions and Warnings on abrasive material being sprayed. Secure airhose to Airbrush with V-62 Wrench for safety and to prevent air leaks.
Maximum Air Pressure 65 P.S.I.



APPLICATIONS:

The AEC Air Eraser is a versatile instrument that can erase color errors and act as an etching tool. It is used by hobbyists and manufacturers to clean jewelry and fine parts, remove discoloration, rust and corrosion, etch glass or cut monograms. It is used by lithographers to highlight half-tones and erase defects without marring the surface or leaving a smudge. It is used extensively by model railroaders for weathering railcars and accessories.

DENTAL INFORMATION:

Indispensable in occlusal relationship analysis of gold casting. By dulling the high polish on the surface of inlays and crowns it is possible to identify minute occlusal contacts with their opposing teeth, without the discrepancy of any inter-occlusal thickness of material. The dull surface of a casting shows the markings of any tape, carbon or articulating paper with superior fidelity. When adjustments have been made, the surface can be dulled again and further analysis carried out.

OPERATION:

For general erasing, clean dry air at pressures of 30 to 45 p.s.i. may be used. To be sure of satisfactory performance, the MT - Moisture Trap or R-75AR Regulator will remove, within their rated capacity, water, oil and other impurities from your source of air supply. Expect a slight trickle of abrasive to flow out after H-155 Button has been released. This is caused by air pressure in the cup being relieved.

1. Attach airhose coupling to AE-35 Valve Casing.
2. Unscrew AE-23 Cover.
3. Fill cup 3/4 full with clean dry AEX, AE, or SSO abrasive and replace AE-23 Cover on cup. Tighten cover securely.
4. To prevent leaks, do not get any abrasive on the cup threads.
5. Regulate air pressure for erasing on paper surfaces to approximately 30 p.s.i. Use a higher air pressure of 45 to 65 p.s.i. for metal, gold castings, plastic or glass work.
6. Hold the Air Eraser the way you would a pencil. Move the Air Eraser with the AEC-34 Tip about 1/8" to 1/2" above the work surface. Adjust to achieve results desired.
7. Adjust AE-24 Control Screw to the lowest point to avoid excessive use of abrasive.
8. For work requiring fast, heavy abrasive cutting, use AEX Fast Cutting Abrasive and high air pressure. Hold tip of the Air Eraser very close to the working surface to cut faster. Hold at a distance for blending and broad coverage.

COMPRESSORS:

The Paasche "D500" Air Compressors can be used with the AEC Air Eraser at pressures up to 40 p.s.i.

Paasche Airbrush Company

4311 North Normandy Avenue
Chicago, IL 60634-1395

Phone: 773-867-9191 • Fax: 773-867-9198

Website: paascheairbrush.com

E-Mail: info@paascheairbrush.com

PAASCHE - AEC AIR ERASER PARTS LIST

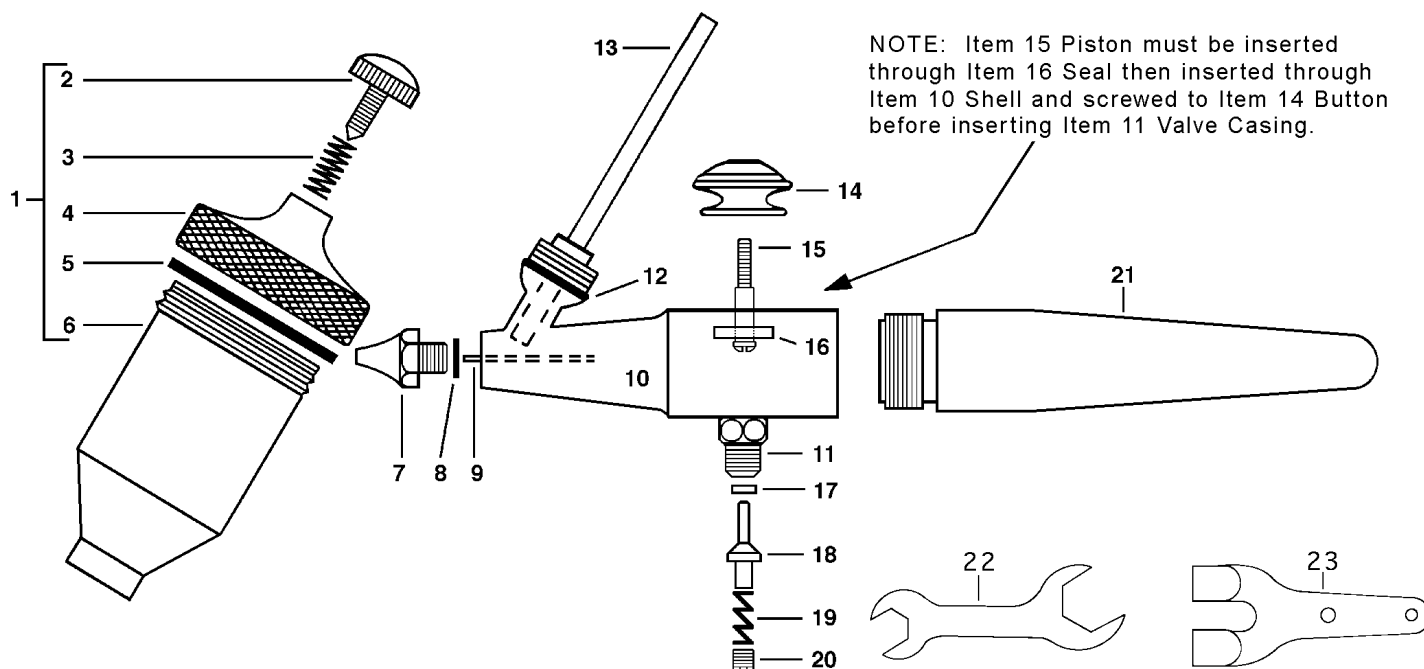

NO.	PART NO.	DESCRIPTION
1.	AE-22	Cup Assembly
2.	AE-24	Control Screw
3.	H-134	Spring
4.	AE-23	Cover
5.	AE-31	Gasket
6.	AE-38	Cup
7.	AEC-34	Tip
8.	AE-43	"O" Ring
9.	AE-32A	Jet
10.	AE-30C	Shell W/ Valve Casing
11.	AE-35	Valve Casing
12.	AE-6	"O" Ring
13.	AE-20	Powder Tube Assembly
14.	H-155	Button
15.	AE-40	Piston (New Style)
16.	AE-39	Seal
17.	A-52	Valve Washer
18.	H-21A	Valve Plunger
19.	AE-61	Valve Spring
20.	A-23A	Air Valve Nut
21.	H-143	Handle

AIR ERASER ABRASIVE COMPOUNDS:

AEX-Fast Cutting Abrasive - (Aluminum Oxide)

- **AEX-6** 6 oz. (170g) Fast Cutting
- **AEX-5** 5 lbs. (2.3k) Fast Cutting
- **AEX-25** 25 lbs. (11.3k) Fast Cutting

AE-Medium Cutting Abrasive - (Pumice)

- **AE-6OZ** 6 oz. (170g) Medium Cutting
- **AE-2** 2 lbs. (906g) Medium Cutting

SSO-Slow Cutting Abrasive - (Starch)

- **SSO-6** 6 oz. (170g) Slow Cutting
- **SSO-2** 1-1/2 Lbs. (679g) Slow Cutting

EXTRA OPTIONS:

- 2DS** Softseal Disposable Respirator
- A-1/8-8MT** Air Hose W/MT Moisture Trap
- R-75AR** Regulator & Filter W/Gauge

CAUTION: It is recommended that a **2DS** Respirator be worn or Ventilation be used to remove excess abrasive.

ACCESSORIES:

22.	V-62	Wrench
23.	A-34	Hanger