



A-CU & F87-CUAD Automatic Spray Guns

OPERATING INSTRUCTIONS & REPLACEMENT PARTS

DESCRIPTION: The A-CU and F87-CUADF Automatic Spray Guns, are medium duty and heavy duty air actuated production spray guns, they will cover a range of materials to include heavy type lacquers and enamels, abrasives or pigmented material. See Page 2 for many styles of Spray Heads and Page 4 for information on circulating fluid bodies. **When using Extensions, material must be pressure fed for proper application.**

CONNECTIONS: Spray Guns have the following: Air inlet 1/4" N.P.T (F) and Fluid inlet 3/8" N.P.T. (M).

PACKING WASHERS: Packings are available in oil treated Leather or Teflon® for natural lubricity and higher temperatures. See Page 3.

OPERATION:

1. Mount Spray Gun in desired position.
2. Blow out all hoses (airlines) before connecting to Spray Gun to remove foreign particles.
3. Connect hose from air supply to air inlet fitting.
4. Connect fluid supply to fluid inlet.
5. Tighten all hose connections securely.
6. Adjust air pressure to desired amount at the Air Regulator.
7. Adjust Fluid volume by turning the U-3178 Fluid Adjusting Knob to the left or right. **Note: Do not use as shutoff by turning all the way down, it may split the tip.**
8. Adjust to proper fan pattern by turning the U-2065 Fan Control Screw to left or right. For AD-2 Air Dial Assembly adjustment, turn U-959B Adjusting Needle Valve left or right.

TIP REPLACEMENT:

1. Turn off Air and Fluid Pressure.
2. Release Fluid Needle (A-U-4") pressure from seat of Tip by taking off the U-2686A Cylinder Cap Assembly.
3. Loosen U-1649 Aircap Nut and remove Multiplehead Assembly. Leave Needle in place.
4. Unscrew U-Tip and place new U-Tip in position.
5. To reassemble reverse above procedure.

MAINTENANCE: Requirements of the A-CU & F87-CUADF Automatic Spray Guns have been reduced to a minimum. The leather packing washers should be lubricated with light oil or replaced once a month. Old packing washers cause leakage of air and Fluid. Teflon® Packings are self-lubricating.

CLEANING: After each use flush clean solvent through the fluid passages of the Spray Gun and Wipe off the outside with clean solvent. Never leave the entire Spray Gun immersed in solvent. Dirty Aircaps and Tips should be cleaned by soaking in solvent and blown clean with air.

Paasche Airbrush Company

4311 North Normandy Avenue
Chicago, IL 60634-1395

Phone: 773-867-9191 • Fax: 773-867-9198

Website: paascheairbrush.com

E-Mail: info@paascheairbrush.com

WARNING: Spray materials may be harmful if inhaled or allowed to come into contact with the skin or eyes. Consult the product label and Material Safety Data Sheet supplied for the spray material. Follow all safety precautions.
CAUTION: Well Ventilated Area Required to remove fumes, dust or overspray. Secure airhose and fluid hose wrench tight for safety and to prevent leaks.
Maximum Air Pressure 100 P.S.I.
Maximum Fluid Pressure 45 P.S.I.

TROUBLE SHOOTING SPRAY PATTERNS:

- (A) A **ROUGH OR STIPPLED FINISH** is caused by low or restricted flow of air pressure or too heavy materials being applied with gun too close to surface.
- (B) A **WET OR SAGGING FINISH** is due to low air pressure or restricted flow of air, material being too thin, or applied too close to the surface.
- (C) A **SPUTTERING SPRAY** is caused by air leaking into fluid line or can be caused by a loose fluid tip, a broken or split tip, lumpy material, a clogged vent hole in cover of material cup, or air leak at fluid pipe attached to inside of tank cover, or a clogged paint strainer. Sputtering may also be caused by worn packing washers, or worn or scored needle.
TO CORRECT: Tighten tip securely or replace. Strain material and clean strainer. Tighten fluid pipe in tank or replace packings and needle in Spray Gun.
- (D) AN **ARCHED FAN SPRAY PATTERN** is caused by dried material accumulated in one fan port of the multiplehead, distorting the pattern.
TO CORRECT: Dissolve material inside fan port with suitable solvent applied with a small brush.
NOTE: Never use wire or sharp instruments to clean Fan Ports as permanent damage to the fan ports will result in destroying uniformity of the Fan Pattern.
- (E) **UNBALANCED FAN SPRAY PATTERN**, heavy on one side, may be caused by material collecting around outside of the fluid tip and aircap, or by a loose aircap.
TO CORRECT: Remove aircap and clean fluid tip and aircap with solvent then dry with air. Always be sure fan aircap and aircap body are tightened securely.
- (F) A **HEAVY CENTER** in a fan pattern is caused by insufficient air pressure at the fan port. Rough or shady edges are also caused by low air pressure.
TO CORRECT: Increase air line pressure.
- (G) A **SPLIT FAN SPRAY PATTERN**, heavy on each end and light in the center, is caused by excessive air pressure.
TO CORRECT: Reduce air pressure.

SPRAY PATTERNS:



SPRAY HEAD COMPONENTS

Spray Heads for A-CU & F87-CUAD Automatic Spray Guns are available in several different styles, some of which are available with Stainless Steel components. The C.F.M. requirements range from 3 to 24 C.F.M. @ 40 to 50 lbs. air pressure. NOTE: When either fluid Tip or fluid Needle is worn and requires replacement, it is recommended that both items be changed for best results. All Tips and Needles are made using 303 Stainless Steel. Carbide Tips & Needles are available for use with abrasive materials. When using Extensions, material must be pressure fed for proper application of material.

EXTERNAL- FAN PATTERN

- **Application:** Broad coverage - High Production.
- **Sizes:** 000-3, 00-4, 00-4-6, 06, 0-9, 2-8, 4-10, 4-15.
- **Fluid Viscosity:** Light to Heavy (3 to 24 C.F.M. @ 40 or 50 P.S.I.)
 1. **56FA-** Aircap Body (Select Size above)
 2. **U-2639S** Sleeve & Spring
 4. **U-1649** Aircap Nut
 5. **U-** Stainless Tip (Select Size 000,00,0,2,4)
 6. **A-U-4** Stainless Needle

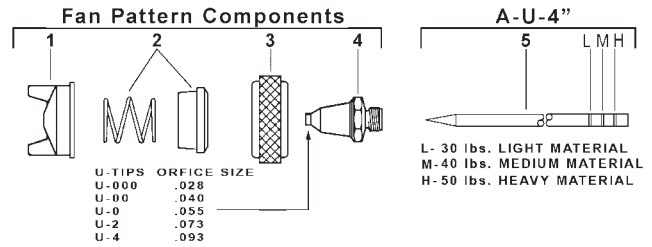

INTERNAL- ROUND PATTERN

- **Application:** Narrow trim, inside crevice, dot, line, High Production.
- **Sizes:** 2-5, 4-6.
- **Fluid Viscosity:** Light to Medium (3 to 6 C.F.M. @ 40 P.S.I.)
 1. **56RA-** Aircap Body (Select Size above)
 2. **U-1649** Aircap Nut
 3. **U-** Stainless Tip (Select Size 2 or 4)
 4. **A-U-4** Stainless Needle

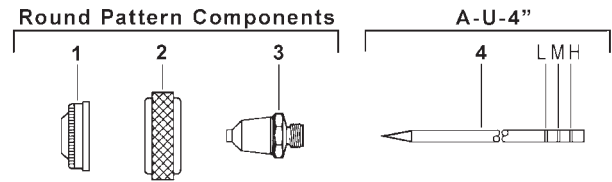

CARBIDE INSERT- FAN PATTERN

- **Application:** Abrasive Materials
- **Sizes:** 0-9, 2-8 or 4-10
- **Fluid Viscosity:** Light to Medium (4 to 12 C.F.M. @ 40 or 50 P.S.I.)
 1. **56CFA-** Aircap Body (Select Size above)
 2. **U-2639S** Sleeve & Spring
 3. **U-1649** Aircap Nut
 4. **UC-** Carbide Insert Stainless Body Tip (Select Size 0, 2 or 4)
 5. **A-UC-4** Carbide Insert Stainless Needle

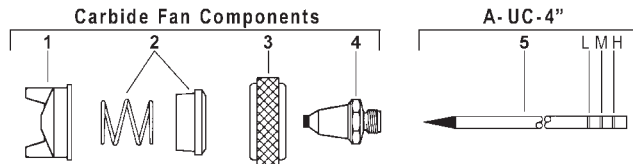

CARBIDE INSERT- ROUND PATTERN

- **Application:** Abrasive Materials
- **Sizes:** 2-5 & 4-6
- **Fluid Viscosity:** Light to Medium (3 to 6 C.F.M. @ 40 P.S.I.)
 1. **56CRA-** Aircap Body (Select Size above)
 2. **U-1649** Aircap Nut
 3. **UC-** Carbide Insert Stainless Body Tip (Select Size 2 or 4)
 4. **A-UC-4** Carbide Insert Stainless Needle

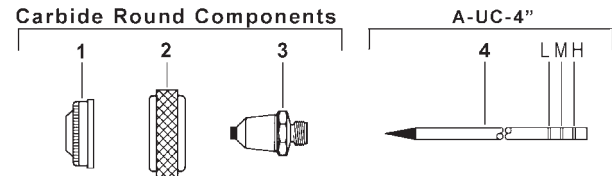

STAINLESS STEEL- FAN PATTERN

- **Application:** Corrosive materials and Latex.
- **Sizes:** 0-6, 0-9, 2-8, 4-10, 4-20-3.
- **Fluid Viscosity:** Light to Medium Heavy (4 to 20 C.F.M. @ 40 or 50 P.S.I.)
 1. **56SFA-** Stainless Aircap Body (Select Size above)
 2. **U-2639P** Poly Sleeve
 3. **U-1649** Aircap Nut (plated brass)
 4. **U-** Stainless Tip (Select Size 0, 2 or 4)
 5. **A-U-4** Stainless Needle

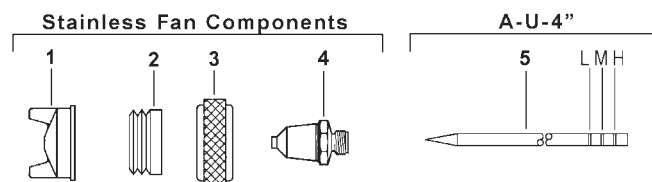

A-CU AND F87-CUAD

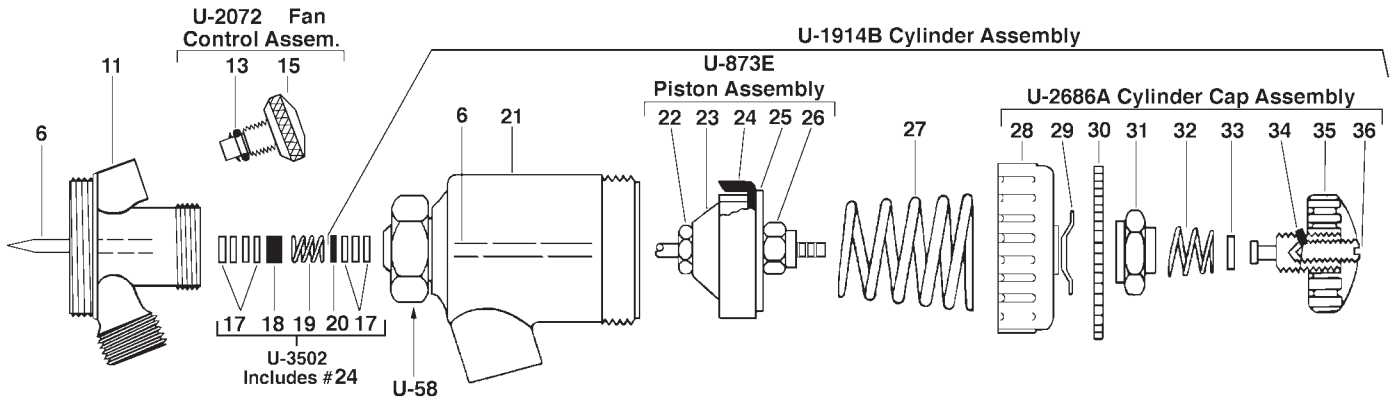

11. **CU-7B** Fluid Body

U-2072A Fan Control Assembly

- 13. **AE-43** "O" Ring (1)
- 15. **U-2065** Fan Control Screw

U-3502 Packing Set

- 17. **U-28-12** Packing Washers (12)
- 18. **U-29** Packing Gland (1)
- 19. **DU-30** St. St. Spring (1)
- 20. **U-203** Gland (1)
- 24. **U-322** Cup Leather (1)

U-1914B Cylinder Assembly

- 6. **A-U-4** Needle
- 20. **U-203** Gland †
- 17. **U-28-12** Packing Washers (3) †
- 21. **U-1907B** Shell Assembly
- 27. **U-2966** Piston Spring

U-873E Piston Assembly

- 22. **U-2965** Needle Chuck
- 23. **U-2964** Inner Bushing
- 24. **U-322** Cup Leather †
- 25. **U-2465A** Outer Disc
- 26. **U-2544** Locknut

U-2686A Cylinder Cap Assembly

- 28. **U-2707A** Cylinder Cap
- 29. **U-941** Spring Washer
- 30. **U-951B** Fluid Dial
- 31. **U-2675A** Friction Nut
- 32. **U-1098** St. St. Spring
- 33. **U-2584P** Washer
- 34. **59-57** Lock Stud
- 35. **U-3178** Fluid Adjusting Knob ††
- 36. **59-56** Lock Screw

59-30 Teflon® Packing Set

- 37. **U-3353** Packing Teflon® (2)
- 38. **59-24** Packing Teflon® (4)
- 39. **59-25B** Packing Expander (2)
- 19. **DU-30** St. St. Spring (1)

59-30 Packing Set

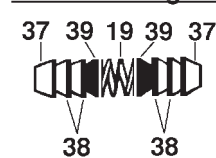

59-68 Teflon® Piston Assembly

- 22. **U-2965** Needle Chuck
- 26. **U-2544** Locknut
- 40. **59-63** Piston
- 41. **59-64** Piston Rings (2)
- 42. **59-65** Expansion Spring

59-68 Piston Assembly

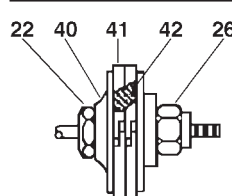

AD-2 Air Dial Assembly - used on F-87-CUAD

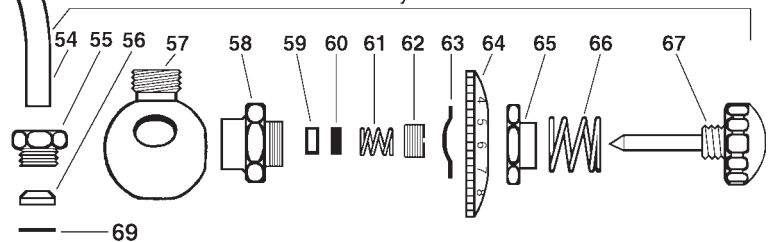

AD-2 Air Dial Assembly

- 54. **U-3255** Use N-1/4 & U-3321 Tube Assembly
- 55. **U-3256** Packing Nut
- 56. **U-3257** Teflon® Packing
- 57. **U-3258** Air Valve Body
- 58. **U-2734A** Packing Housing
- 59. **DU-28-12** Packing Washers (1)
- 60. **U-27** Packing Gland
- 61. **U-1702** Valve Spring
- 62. **U-48** Strainer Nut
- 63. **U-941** Spring Washer
- 64. **PA-14A** Dial
- 65. **U-2675A** Friction Nut
- 66. **U-1098** Spring St. St.
- 67. **U-959** Adjusting Needle Valve
- 69. **U-3548** Packing Washer

- 52. **US- 0, 2 or 4** Self Cleaning Tip (US-0 same as U-0)
- 53. **A-US-0-4, 2-4, 4-4** Self Clean Needle Use to prevent buildup in tip & pressure feed.

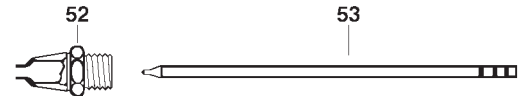

†† **WARNING:** Do not use U-3178 as a shut-off by turning all the way down - it will split the tip.

† This item included in U-3502 Packing Set. **U-28-12 & DU-28-12** sold by the dozen only. DuPont®

F87-CUAD Fluid Body Atomizing Air Dial Control
(Also in Stainless Steel)

- 71. **U-959** Fan Screw
- 72. **U-1098** St. St. Spring
- 73. **U-942** Friction Nut
- 74. **PA-14B** Dial
- 75. **U-941** Spring Washer
- 76. **U-957** Bushing
- 77. **DU-30** St. St. Spring (2)
- 78. **U-27** Packing Gland (2)
- 79. **DU-28-12** Packing Washer (1) †
- 80. **87-20** Fluid Body
- 81. **U-28-12** Packing Washer (4) †
- 82. **U-29** Packing Gland

CU- Fluid Bodies

- 83. **CU-7B** Standard
- CUS-7B** Standard Stainless Steel
- 84. **CUA-7B** Separate Atomizing
- CUSA-7B** Separate Atomizing Stainless St.
- 85. **CUG-7B** Circulating Fluid

† U-28-12 & DU-28-12 Packing Washers sold by dozen only.
Teflon® Needle Packings and Piston Rings are available
Teflon Needle Packings & Piston add **XX** after A or F87

ATOMIZING AIR DIAL CONTROL

