

Paasche® A-BU

AUTOMATIC SPRAY GUNS

OPERATING INSTRUCTIONS AND REPLACEMENT PARTS

INSTRUCTIONS AND PARTS LIST A-BU-10/2007
Supersedes Instructions & Parts List A-BU-5/2006

WARNING: Spray materials may be harmful if inhaled or allowed to come into contact with the skin or eyes. Consult the product label and Material Safety Data Sheet supplied for the spray material. Follow all safety precautions.
CAUTION: Well Ventilated Area Required to remove fumes, dust or overspray. Secure airhose and fluid hose wrench tight for safety and to prevent leaks.
Maximum Air Pressure 100 P.S.I.
Maximum Fluid Pressure 45 P.S.I.

DESCRIPTION:

The A-BU- Automatic Spray Gun, a medium duty air actuated production spray gun, will cover a range of materials to include light lacquers, abrasives or latex and corrosives.

AIR AND FLUID CONNECTIONS:

Air Inlet 1/4" N.P.T. (Female) and Fluid Inlet 3/8" N.P.T. (Male). A-BU- Automatic Spray Gun dimensions are 5-1/8"L x 2-1/4"D. Packing Washers are treated leather and soaked in oil. For Teflon® Packings see page 3.

OPERATION:

1. Mount Gun in desired position.
2. Blow out all hoses before connecting to spray gun to remove foreign particles.
3. Connect hose from air supply to air inlet fitting.
4. Connect fluid supply to fluid inlet.
5. Tighten all hose connections securely.
6. Adjust air pressure to desired amount at the air regulator.
7. Adjust fluid volume by turning the U-3178 Fluid Adjusting Knob to the left (Increase) or right (Decrease).

NOTE: DO NOT USE AS A SHUT-OFF BY TURNING ALL THE WAY DOWN, IT MAY SPLIT THE TIP.

TIP REPLACEMENT:

1. Turn off air pressure and fluid pressure.
2. Release needle pressure from the seat of fluid tip by taking off the U-2686A Cylinder Cap Assembly. This will relieve the spring pressure.
3. Loosen BU-12 Aircap Nut and remove Spray Head assembly. Leave A-U-4 Needle in place.
4. Unscrew U- Tip. Place new tip in position.
5. When replacement is complete reassemble by reversing the above procedure.

MAINTENANCE:

Requirements of the A-BU- Automatic Spray Gun have been reduced to a minimum. The leather packing washers should be lubricated once a month with a light oil. Old packing washers cause leakage of air or fluid and replacement should be made on a regular schedule. Teflon® Packings are available and are self lubricating.

CLEANING:

Flush appropriate solvent through fluid passages of the Spray Gun and wipe off the outside with a clean cloth. Never leave the entire Spray Gun immersed as this will ruin leather packings. Dirty aircaps and tips should be cleaned by soaking, then drying.

TROUBLE SHOOTING SPRAY PATTERNS:

- A. A ROUGH OR STIPPLED FINISH is caused by low or restricted flow of air pressure or too heavy materials being applied with gun too close to surface.
- B. A WET OR SAGGING FINISH is due to low air pressure or restricted flow of air, material being too thin, or applied too close to the surface.
- C. A SPUTTERING SPRAY can be caused by air leaking into fluid line, a loose fluid tip, a broken or split tip, lumpy material, a clogged vent hole in cover of material cup, an air leak at fluid pipe attached to inside of A.S.M.E. Tank cover, or a clogged paint strainer. Sputtering may also be caused by worn packing washers, or worn or scored needle.
TO CORRECT: Tighten tip securely or replace. Strain material and clean strainer. Tighten fluid pipe in tank or replace packings and needle in Spray Gun.
- D. AN ARCHED FAN SPRAY PATTERN is caused by dried material accumulated in one fan port of the fan aircap, distorting the pattern.
TO CORRECT: Dissolve material inside fan port with suitable solvent applied with a small brush.
NOTE: Never use wire or sharp instruments to clean Fan Ports as permanent damage to the fan ports will result in destroying uniformity of the fan pattern.
- E. UNBALANCED FAN SPRAY PATTERN, heavy on one side, may be caused by material collecting around outside of the fluid tip and aircap, or by a loose aircap.
TO CORRECT: Remove aircap and clean fluid tip and aircap with solvent then dry with air. Always be sure fan aircap and aircap body are tightened securely.
- F. A HEAVY CENTER in a fan pattern is caused by insufficient air pressure at the fan port. Rough or shady edges are also caused by low air pressure.
TO CORRECT: Increase air line pressure.
- G. A SPLIT FAN SPRAY PATTERN, heavy on each end and light in the center, is caused by excessive air pressure.
TO CORRECT: Reduce air pressure.

SPRAY PATTERNS:



Paasche Airbrush Company

4311 North Normandy Avenue
Chicago, IL 60634-1395

Phone: 773-867-9191 • Fax: 773-867-9198

Website: paascheairbrush.com

E-Mail: info@paascheairbrush.com

Printed in the U.S.A.

Spray Heads for **A-BU-** Automatic Spray Guns are available in several different Styles, some of which are available with Stainless Steel components. The C.F.M. requirements range from 2 to 14 C.F.M. @ 30 to 40 lbs. air pressure. NOTE: When either fluid Tip or fluid Needle is worn and requires replacement, it is recommended that both items be changed for best results. All Tips and Needles are made using 303 Stainless Steel. Carbide Tips and Needles are available for use with abrasive materials.

• **EXTERNAL- FAN PATTERN**

- **Sizes:** 2 or 4
- **Application:** Application in tight areas - fast color change.
- **Fluid Viscosity:** Light to Medium (2 to 6 C.F.M. @ 30 P.S.I.)
 1. **BNFA-** Fan Aircap (Select Size)
 2. **BU-12** Aircap Nut
 3. **U-** Stainless Tip (Select Size)
 4. **A-U-4** Stainless Needle

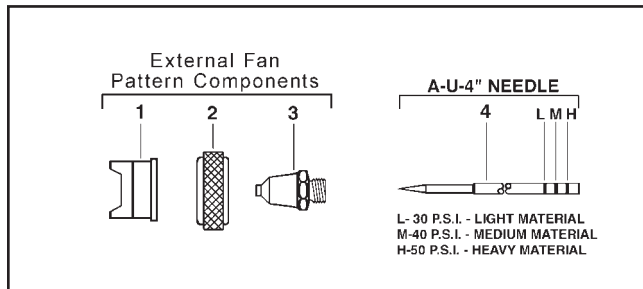

• **INTERNAL- ROUND PATTERN**

- **Sizes:** 2 or 4
- **Application:** Fine lines, detailing stenciling and touch-up.
Latex, silver nitrate, acidic materials.
- **Fluid Viscosity:** Light to medium (2 to 3.5 C.F.M. @ 40 P.S.I.)
 1. **BR-15-** Aircap Body (Select Size)
 2. **BU-12** Aircap Nut
 3. **U-** Stainless Tip (Select Size)
 4. **A-U-4** Stainless Needle

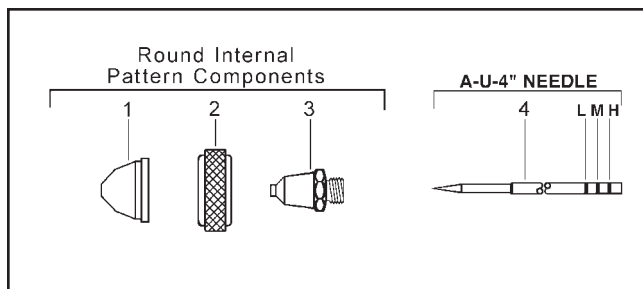

• **STAINLESS- INTERNAL- ROUND PATTERN**

- **Sizes:** 2 or 4
- **Application:** Fine lines, detailing stenciling and touch-up.
Latex, silver nitrate, acidic materials.
- **Fluid Viscosity:** Light to medium (2 to 3.5 C.F.M. @ 40 P.S.I.)
 1. **BSR-15-** Stainless Aircap Body
 2. **BUS-12** Stainless Aircap Nut
 3. **U-** Stainless Tip (Select Size)
 4. **A-U-3-1/32** Stainless Needle

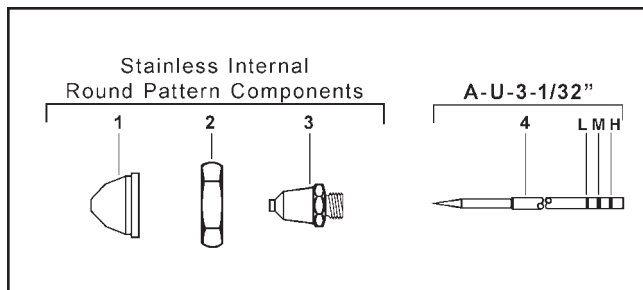

• **STAINLESS- EXTERNAL- FAN PATTERN**

- **Sizes:** 0 only
- **Application:** Corrosive materials.
- **Fluid Viscosity:** Light to Medium (3 to 5 C.F.M. @ 40 P.S.I.)
 1. **BSF-15-** Stainless St. Fan Aircap (Select Size)
 2. **BUS-12** Stainless St. Aircap Nut
 3. **U-** Stainless Tip (Select Size)
 4. **A-U-4** Stainless Needle

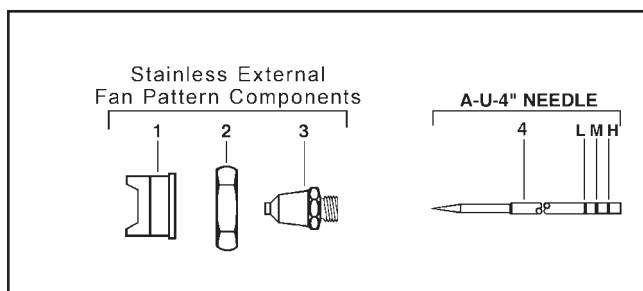

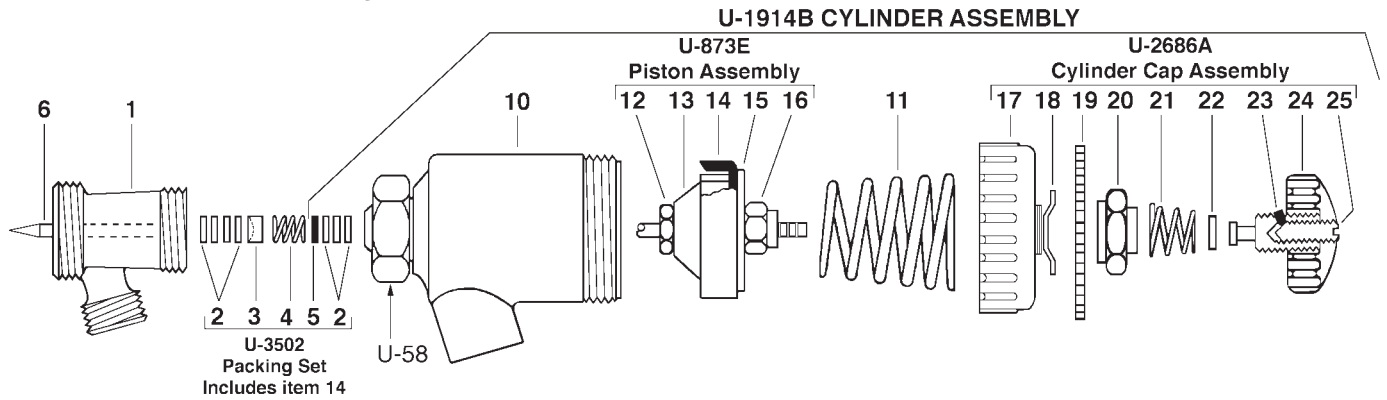

BU- Fluid Bodies

- 1. **BU-7B** Standard
- BUS-7B** Standard Stainless Steel
- 1d. **BU-7DA** Atomizing Air Dial Control

U-3502 Packing Set

- 2. **U-28-12** Packing Washers (Dozen)
- 3. **U-29** Packing Gland (1)
- 4. **DU-30** Spring (1)
- 5. **U-203** Gland (1)
- 14. **U-322** Cup Leather (1)

U-1914B Cylinder Assembly

- 6. **A-U-4** Needle
- 5. **U-203** Gland
- 2. **U-28-12** Packing Washers (3)
- 10. **U-1907B** Shell
- 11. **U-2966** Piston Spring

U-873E Piston Assembly

- 12. **U-2965** Needle Chuck
- 13. **U-2964** Inner Bushing
- 14. **U-322** Cup Leather
- 15. **U-2465A** Outer Disc
- 16. **U-2544** Locknut

U-2686A Cylinder Cap Assembly

- 17. **U-2707A** Cylinder Cap
- 18. **U-941** Spring Washer
- 19. **U-951B** Fluid Dial
- 20. **U-2675A** Friction Nut
- 21. **U-1098** Spring
- 22. **U-2584P** Washer
- 23. **59-57** Lock Stud
- 24. **U-3178** Fluid Adjusting Knob †
- 25. **59-56** Lock Screw

† **NOTE:** Do not use as a shut-off by turning all the way down. This may damage the tip.

59-30 Teflon® Packing Assembly

- 26. **U-3353** Packing Teflon® (2)
- 27. **59-24** Packing Teflon® (4)
- 28. **59-25B** Expander (2)
- 29. **DU-30** Spring (1)

59-68 Teflon® Piston Assembly

- 30. **U-2965** Needle Chuck
- 31. **59-63** Aluminum Piston
- 32. **59-64** Teflon® Piston Ring(2)
- 33. **59-65** Expansion Spring
- 34. **U-2544** Locknut



59-68 Teflon® Piston Assembly

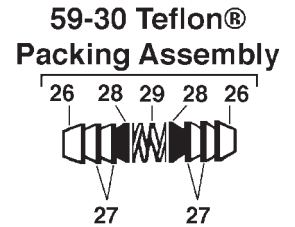
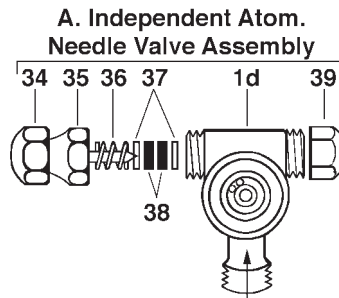
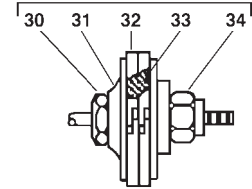

B. Atomizing Air Dial Control

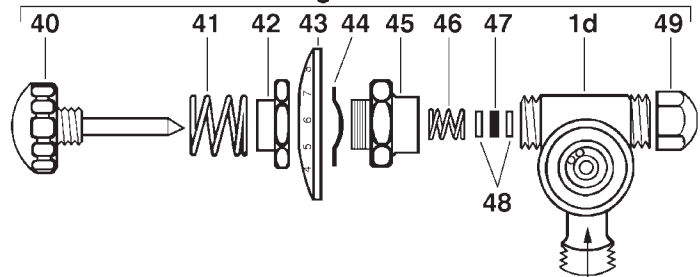

A. Independent Atomizing Needle Valve Body Assembly

- 34. **U-166A** Needle Valve Assem.
- 35. **U-167** Spring Cap
- 36. **DU-30** Spring
- 37. **U-203** Gland (2)
- 38. **U-28-12** Packing Washers (2)
- 1d. **BU-7DA** Fluid Body
- 39. **U-551** Cap Nut

B. Atomizing Air Dial Control

- 40. **U-959** Air Adjusting Needle
- 41. **U-1098** Spring
- 42. **U-942** Friction Nut
- 43. **PA-14** Dial
- 44. **U-941** Spring Washer
- 45. **U-957** Bushing
- 46. **DU-30** Spring
- 47. **U-27** Packing Gland (1)
- 48. **DU-28-12** Packing Washers (2)
- 1d. **BU-7DA** Fluid Body
- 49. **U-551** Cap Nut

• **U-28-12** and **DU-28-12** Packing Washers sold by the dozen (12) only.

Teflon® Needle Packings and Pistons are available in any model at additional charge.

- Add letter: "X" after A for Teflon Needle Packings Only.
Example: A-BUF-2 becomes **AX-BUF-2**.
- Add letters: "XX" after A for Teflon Needle Packings and Piston.

HA- NYLON REINFORCED
RUBBER COVERED FLUID HOSE



HT- BRAID COVERED RUBBER AIR HOSE



BOTH FLUID & AIR HOSES HAVE
MAXIMUM WORKING AIR PRESSURE OF 100 LBS.



Automatic Hook-Up

INSTRUCTIONS:

Blow out all the hoses to remove foreign particles. Make Air and Fluid connections as shown. Tighten fittings securely. Strain material before placing in tank.

1. Air Compressor must have sufficient capacity for application.
2. Air Regulator; adjust pressure required to operate Striping Gun, Approximately 45 P.S.I.
3. Explosion-proof Solenoid Valve with air dump feature, mount as close to Gun as possible for fast on-off action.
4. Pressure Tank GT-25; adjust Regulator on Tank Unit to minimum pressure required to deliver fluid to Striping Gun #5.

