

SA2000 Airbrush for Hobbies & Crafts Single Action / Internal Mix

WARNING: Spray materials may be harmful if inhaled or allowed to come into contact with the skin or eyes. Consult the product label and Material Safety Data Sheet supplied for the spray material. Follow all safety precautions.
CAUTION: Well Ventilated Area Required to remove fumes, dust or overspray. Secure airhose to Airbrush with V-62 Wrench for safety and to prevent air leaks.
Maximum Air Pressure 75 P.S.I.

OPERATING INSTRUCTIONS AND REPLACEMENT PARTS

INTRODUCTION:

The **SA2000** Airbrush is simple in design and operation. Ideal for Hobbyists and Crafters that are just learning to use an Airbrush.

OPERATING INSTRUCTIONS:

Adjustments in the flow of color are made by turning the Needle Chuck (#12) in to decrease, or out for increased flow. To spray, press the Finger Button (#8).

To disassemble, loosen the Needle Locknut (#13) by holding the Needle Chuck (#12) firmly so it will not turn. Unscrew the Needle Chuck from the Red Handle (#11) and remove the Handle. Now carefully remove the Needle (#6)

and then the Finger Button Assembly. **Note:** The angled hole in the Finger Button Stem (#9) as you remove it because it must be replaced with the angle of the hole in line with the Needle (#6). The Aircap (#3), Aircap Body (#4) and Tip (#5) may now be removed. Reassembly should always be done with care, especially when reinserting the Needle. Reverse the procedure used for disassembly. After the Needle has been gently pushed forward into the tip, assemble the Needle Chuck (#12) and screw it in firmly. Hold the Needle Chuck while screwing the Needle Locknut (#13) down to lock the needle. Caution should always be used when reinserting the Needle - too much pressure can damage the tip.

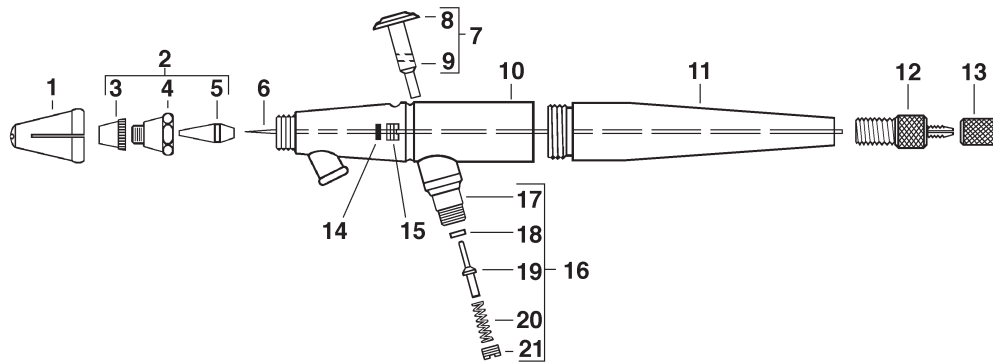

<u>No.</u>	<u>Part No.</u>	<u>Description</u>	<u>No.</u>	<u>Part No.</u>	<u>Description</u>
1.	VL-189	Head Protecting Cap	11.	SA-208	Handle
2.	VLM-1, 3 or 5	Multiplehead (Select Size)	12.	SA-211	Needle Chuck
3.	VLA-1, 3 or 5	Aircap (Select Size)	13.	SA-212	Needle Locknut
4.	VLB	Aircap Body	14.	MU-61	Packing Washer
5.	VLT-1, 3 or 5	Tip (Select Size)	15.	MU-62	Packing Nut
6.	SAN-1, 3 or 5	Needle-Extra Length	16.	VL-176	Air Valve Assembly
7.	SA-206	Finger Button Assembly	17.	VL-20	Valve Casing
8.	VL-135A	Finger Button	18.	A-52	Valve Washer (Price/Doz.)
9.	SA-207	Finger Button Stem	19.	H-21A	Valve Plunger
10.	SA-210	Shell Assembly	20.	A-22	Valve Spring
	VL-20	Valve Casing (Included)	21.	A-23A	Air Valve Nut

Paasche Airbrush Company
 4311 North Normandy
 Chicago, IL 60634-1395
 Phone: 773-867-9191 • Fax: 773-867-9198
 Website: paascheairbrush.com
 E-Mail: info@paascheairbrush.com